

<p><b>(D)</b> Ersatzteilliste</p>	<p><b>Sprühgerät</b></p>	<p><b>450</b></p>	<p><b>Inhaltsverzeichnis</b></p>	<p>Seite</p>
	Bestell-Nr.:		Kurbelgehäuse, Kurbelwelle, Kolben	2
	400015001 (12 Liter Behälter)		Vergaser	3
	400015002 (20 Liter Behälter)		Auspuff, Zündmodul	4
			Starter	5
			Gebläsegehäuse	6
			Luftfilter, Motorabdeckung	7
			Tragegestell	8
			Benzintank, Bodenlatte	9
			Behälter	10
			Blasrohr, Handgriff	11
			Ersatzteile, Bestell-Richtlinien	12
<p><b>(GB)</b> Spare parts list</p>	<p><b>Mistblower</b></p>	<p><b>450</b></p>	<p><b>Table of contents</b></p>	<p>Page</p>
	Order-No.:		Crank case, crankshaft, piston	2
	400015001 (12 l tank frame)		Carburetor	3
	400015002 (20 l tank frame)		Exhaust, coil	4
			Recoil starter	5
			Fan housing	6
			Air cleaner, cover cylinder	7
			Frame	8
			Fuel tank, bottom plate	9
			Tank frame	10
			Air Tube, handle	11
			Spare parts, directions for ordering	12
<p><b>(F)</b> Liste de pièces de rechange</p>	<p><b>Atomiseur</b></p>	<p><b>450</b></p>	<p><b>Table des matières</b></p>	<p>Page</p>
	No. de Cde.:		Carter de manivelle, vilebrequin, piston	2
	400015001 (12 l support de réservoir)		Carburateur	3
	400015002 (20 l support de réservoir)		Echappement, bobine	4
			Lanceur	5
			Carter de turbine	6
			Filtre à air, capôt cylindre	7
			Châssis	8
			Réservoir d'essence, plaque basse	9
			Support de réservoir	10
			Tube de soufflerie, guidon	11
			Pièces de rechange, directives pour les commandes	12
<p><b>(E)</b> Lista de piezas de recambio</p>	<p><b>Atomizador</b></p>	<p><b>450</b></p>	<p><b>Indice</b></p>	<p>Página</p>
	Ref.-Nr.:		Carter cigüenal, cigüenal, piston	2
	400015001 (12 l depósito)		Carburador	3
	400015002 (20 l depósito)		Escape, bobina	4
			Arranque	5
			Carter de turbina	6
			Filtro de aire, cubierta	7
			Bastidor	8
			Deposito gasolina, chapa	9
			Depósito	10
			Tubo soplador, empuñadura	11
			Piezas de recambio, directives de pedido	12



Bild-Nr. Pos.-No. Pos.-No.	Bestell-Nr. Order-No. No. de Cde Ref.-Nr.	Menge Quantity Nombres Cantidad	<b>Kurbelgehäuse, Kurbelwelle, Kolben</b>	<b>Crank case, crankshaft, piston</b>	<b>Carter de manivelle, vilebrequin, piston</b>	<b>Carter cigüenal, cigüenal, piston</b>
1	20 00 474	1	Motor enth. (-> 1 - 23)	Engine incl. (-> 1 - 23)	Moteur y inclus (-> 1 - 23)	Motor incl. (-> 1 - 23)
2	20 74 295	2	Lagerhülse 34,9x45,17x17,2 mm	Sleeve	Douille	Casquillo
3	00 54 220	2	Wellendichtring 15x28x5 mm	Oil seal	Joint spy	Reten
4	00 50 102	2	Kugellager 15x35x11mm	Ball bearing	Roulement à billes	Cojinete de bolas
5	00 31 375	2	Scheibe 15,3x22x0,5 mm	Washer	Rondelle	Arandela
6	22 00 109	1	Kurbelwelle	Crankshaft	Vilebrequin	Cigüenal
7	00 52 226	1	Nadelkäfig 9x13x12,5 mm	Needle bearing	Roulement à aiguilles	Casquillo de cojinete
8	00 18 340	6	Zylinderschraube M5x40 mm	Screw	Vis	Tornillo
9	00 72 140	6	Scheibe 5,2x12x0,5 mm	Washer	Rondelle	Muelle de disco
10	21 00 653	1	Kurbelgehäuse	Crankcase	Carter-moteur	Carter de cigüenal
11	20 63 371	1	Dichtungsteil Kurbelgehäuse	Crankcase gasket	Joint carter-moteur	Empaquetadura
12	00 62 290	2	O-Ring 39x3 mm	Ring	Joint torique	Anillo
13	22 00 248	1	Kolben Ø 42,00 mm	Piston	Piston	Piston
14	20 31 117 25	1	Kolbenbolzen 9/6x28	Piston pin	Axe de piston	Bulon de piston
15	00 55 278	2	Sicherungsring 9x0,8 mm	Piston pin circlip	Circlip axe piston	Anillo
16	20 11 112	1	Nikasilzylinder Ø 42,00 mm	Cylinder	Cylindre	Cilindro
17	00 21 256	2	Vierkantmutter M5	Nut	Écrou	Tuerca
18	23 00 730	1	Zündkerze WSR6F 200	Spark plug	Bougie	Bujia
19	20 61 511	1	Vergaserstutzendichtung	Manifold gasket	Joint de bride	Junta de brida
20	20 74 540	1	Vergaserstutzen Ø i. 12 mm	Manifold	Bride de carburateur	Brida de carburador
21	00 18 338	2	Zylinderschraube 5x25 mm	Screw	Vis	Tornillo
22	00 72 144	2	Sicherungscheibe 5 mm	Tension washer	Rondelle de tension	Arandela elastica
23	40 42 817	2	Lasche (->)	Flap (->)	Collier (->)	Cubrejunta (->)
24	00 18 363	2	Linsenschraube 5x20 mm	Screw	Vis	Tornillo
25	20 74 774	1	Anwurfrolle	Anwurfrolle	Anwurfrolle	Anwurfrolle
26	00 20 104	1	Sechskantmutter M10x1 mm	Nut	Écrou	Tuerca
27	00 34 135	1	Sicherungscheibe 10	Circlip	Arrêtage	Seguro
28	23 00 774	1	Polrad	Flywheel	Volant magnétique	Volante
29	00 75 101	1	Scheibenfeder 3x3,7 mm	Spring washer	Rondelle ressort	Resorte de disco
30	40 43 999	1	Halteblech	Fixing plate	Plaque	Chapa fijacion
31	00 18 372	2	Linsenschraube 6x35 mm	Screw	Vis	Tornillo



Bild-Nr. Pos.-No. Pos.-No. Pos.-No.	Bestell-Nr. Order-No. No. de Cde Ref.-Nr.	Menge Quantity Nombres Cantidad	Vergaser	Carburetor	Carburateur	Carburador
1	00 21 235	2	Vierkantsmutter M5	Nut	Écrou	Tuerca
2	20 61 515	1	Vergaserdichtung 0,7 mm	Carburetor gasket	Joint de carburateur	Junta carburador
3	23 00 805	1	Vergaser WT-552	Carburetor	Carburateur	Carburador
4	20 74 905	1	Haltering	Ring	Bague de retient	Anillo
5	00 62 321	1	O-Ring 42x2,5 mm	Ring	Joint torique	Anillo
6	00 62 325	1	O-Ring 21x1,0 mm	Ring	Joint torique	Anillo
7	49 00 536	1	Bausatz Lufteintritt enth. (-> 7 - 13)	Modification kit incl. (-> 7 - 13)	Kit de modification y inclus (-> 7 - 13)	Juego modificacion incl. (-> 7 - 13)
8	20 74 926	1	Ansaugflansch	Suction flange	Bride	Brida
9	00 10 107	1	Zylinderschraube M5x50 mm	Screw	Vis	Tornillo
10	00 10 595	1	Zylinderschraube M5x60 mm	Screw	Vis	Tornillo
11	00 62 263	1	O-Ring 12x2,5 mm	Ring	Joint torique	Anillo
12	20 74 914	1	Chokeklappe	Choke flap	Étrangleur	Valvula
13	20 74 960	1	Flansch Lufteintritt (-)	Flange (-)	Bride (-)	Brida (-)
14	00 21 256	2	Vierkantsmutter M5	Nut	Écrou	Tuerca
15	20 61 511	1	Vergaserstutzendichtung	Manifold gasket	Joint de bride	Junta de brida
16	20 74 540	1	Vergaserstutzen Ø i. 12 mm	Manifold	Bride de carburateur	Brida de carburador
17	00 18 338	2	Zylinderschraube 5x25 mm	Screw	Vis	Tornillo
18	00 72 144	2	Sicherungsscheibe 5 mm	Tension washer	Rondelle de tension	Arandela elastica
19	40 42 817	2	Lasche	Flap	Collier	Cubrejunta
20	00 64 407	70 mm	Schlauch	Hose	Tuyau	Tube
21	00 64 300	205 mm	Schlauch Benzinrücklauf	Hose	Tuyau	Tube
22	27 00 322	1	Primer	Primer	Primer	Primer
23	00 66 452	1	Stutzen	Socket	Manchon	Munon
24	28 00 566	1	Bowdenzug Gas	Bowden cable gas	Câble bowden gaz	Cable bowden gas
25	05 10 949	1	Dichtsatz-Vergaser WT-552	Gasket-kit-carburetor	Pochette de joints-carburateur	Juego de juntas-carburador
26	05 10 982	1	Reparatursatz-Vergaser WT-552	Repair-kit-carburetor	Kit de réparation-carburateur	Juego de reparacion-carburador
27	05 10 983	1	Drosselachsen-kit-Vergaser WT-552	Throttle axle kit - carburetor	Jeu d'axe - carburateur	Juego de mariposa - carburador

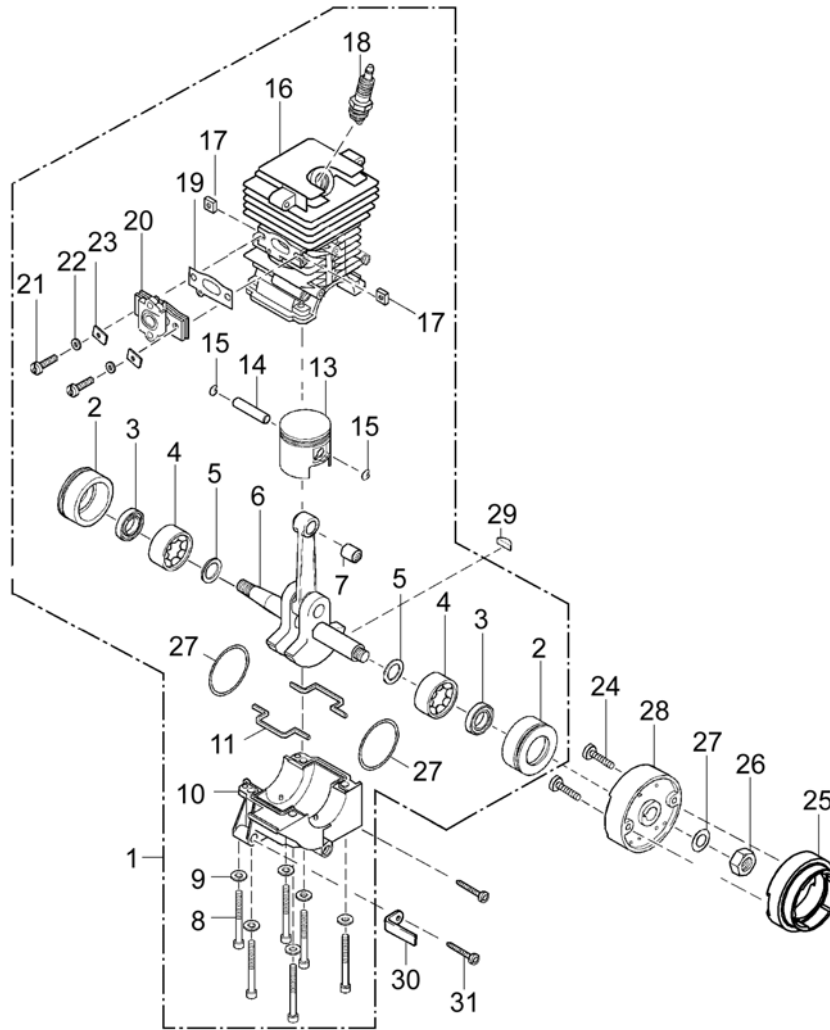

Bild-Nr. Pos.-No. Pos.-No.	Bestell-Nr. Order-No. No. de Cde Ref.-Nr.	Menge Quantity Nombres Cantidad	Auspuff, Zündmodul	Exhaust, coil	Echappement, bobine	Escape, bobina
1	00 18 363	2	Linsenschraube 5x20 mm	Screw	Vis	Tornillo
2	00 72 144	2	Sicherungsscheibe 5 mm	Tension washer	Rondelle de tension	Arandela elastica
3	20 74 562	2	Isolierelement	Insulator	Élément d'isolation	Elemento aislador
4	25 00 749	1	Auspuff	Muffler	Échappement	Escape
5	00 28 100	2	Sechskantmutter M6	Nut	Écrou	Tuerca
6	00 72 143	2	Sicherungsscheibe 6 mm	Tension washer	Rondelle de tension	Arandela
7	20 61 103	1	Auspuffdichtung	Exhaust gasket	Joint échappement	Junta del escape
8	00 18 421	2	Vierkantschraube M6x20 mm	Screw	Vis	Tornillo
9	23 00 730	1	Zündkerze WSR6F 200	Spark plug	Bougie	Bujia
10	23 00 204	1	Zündmodul, kompl., enth. (-> 10 - 14	Ignition coil, compl., incl. (-> 10 - 14	Bobine d'allumage, compl. y inclus (-> 10 - 14	Bobina, compl. incl. (-> 10 - 14
11	00 64 292	200 mm	Schlauch	Hose	Tuyau	Tubo
12	00 84 621	1	Kerzenstecker	Spark plug cap	Capuchon de bougie	Terminal de bujia
13	00 73 347	1	Kontaktfeder	Contact spring	Ressort de contact	Resorte de contacto
14	23 00 203	1	Zündmodul (->)	Ignition coil (->)	Bobine d'allumage (->)	Bobina (->)
15	00 30 135	1	Scheibe 4,3 mm	Washer	Rondelle	Arandela
16	00 72 148	2	Sicherungsscheibe 4 mm	Washer	Rondelle	Disco de tension
17	00 18 326	2	Zylinderschraube M4x16 mm	Screw	Vis	Tornillo
18	00 84 855	1	Massekabel, Kurzschlußkabel	Short-circuit cable	Câble court-circuit	Cable cortocircuito
19	00 84 866	1	Massekabel	Ground cable	Câble de masse	Cable de masa
20	00 72 161	1	Scheibe 4,2x10x0,5 mm	Washer	Rondelle	Arandela
21	00 18 280	1	Zylinderschraube M4x12 mm	Screw	Vis	Tornillo
22	00 66 455	2	Kabelband 98x2,5mm, Natur	Cable band	Frein de câble	Cinta

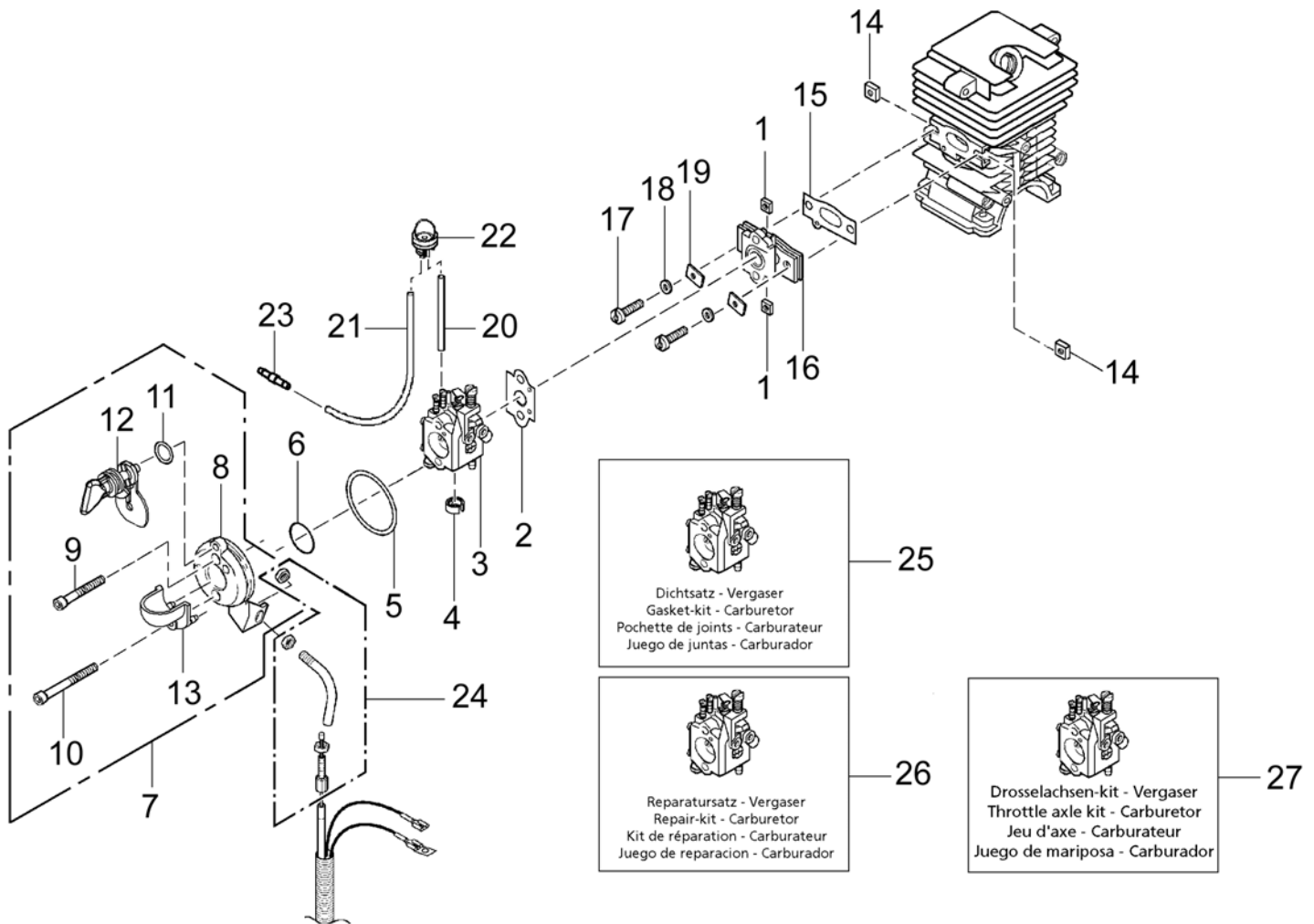

Bild-Nr. Pos.-No. Pos.-No.	Bestell-Nr. Order-No. No. de Cde Ref.-Nr.	Menge Quantity Nombres Cantidad	Starter	Recoil starter	Lanceur	Arranque
1	26 00 106	1	Starter, kompl. enth. (-> 1 - 13	Starter, compl. incl. (-> 1 - 13	Lanceur, compl. y inclus (-> 1 - 13	Arranque, compl. incl. (-> 1 - 13
2	21 00 123	1	Startergehäuse	Starter housing	Carter de lanceur	Carter de arranque
3	00 63 195 25	1	Starterseil 3x1050 mm	Starter rope	Corde de lanceur	Cuerda de arranque
4	20 74 570	1	Startergriff	Starter grip	Poignée lanceur	Empunadura arranque
5	26 00 284	1	Federkassette	Spring cassette	Cassette de ressort	Caja de resorte
6	20 74 915	1	Seilrolle	Rope pulley	Poulie de lanceur	Roldana
7	20 74 343	1	Starterklinke	Starter pawl	Cliquet de lanceur	Trinquete
8	00 31 611	1	Scheibe 4,3x16x1 mm	Washer	Rondelle	Arandela
9	20 74 977	1	Kulisse, rot	Template, red	Coulisse, rouge	Colisa, rojo
10	20 31 965	1	Distanzstück 4,3x12,5x5 mm	Spacer	Butée d'espacement	Espaciador
11	00 73 365	1	Federstecker 1,4	Pin	Goupille beta	Clavija
12	00 18 384	1	Linsenschraube 4x16 mm	Screw	Vis	Tornillo
13	00 34 152	1	Sicherungsscheibe 4S <-)	Circlip <-)	Rondelle <-)	Arandela <-)
14	00 18 258	2	Linsenschraube 5x18 mm	Screw	Vis	Tornillo
15	00 18 338	2	Zylinderschraube M5x25 mm	Screw	Vis	Tornillo
16	00 72 144	2	Sicherungsscheibe 5 mm	Circlip	Rondelle	Arandela

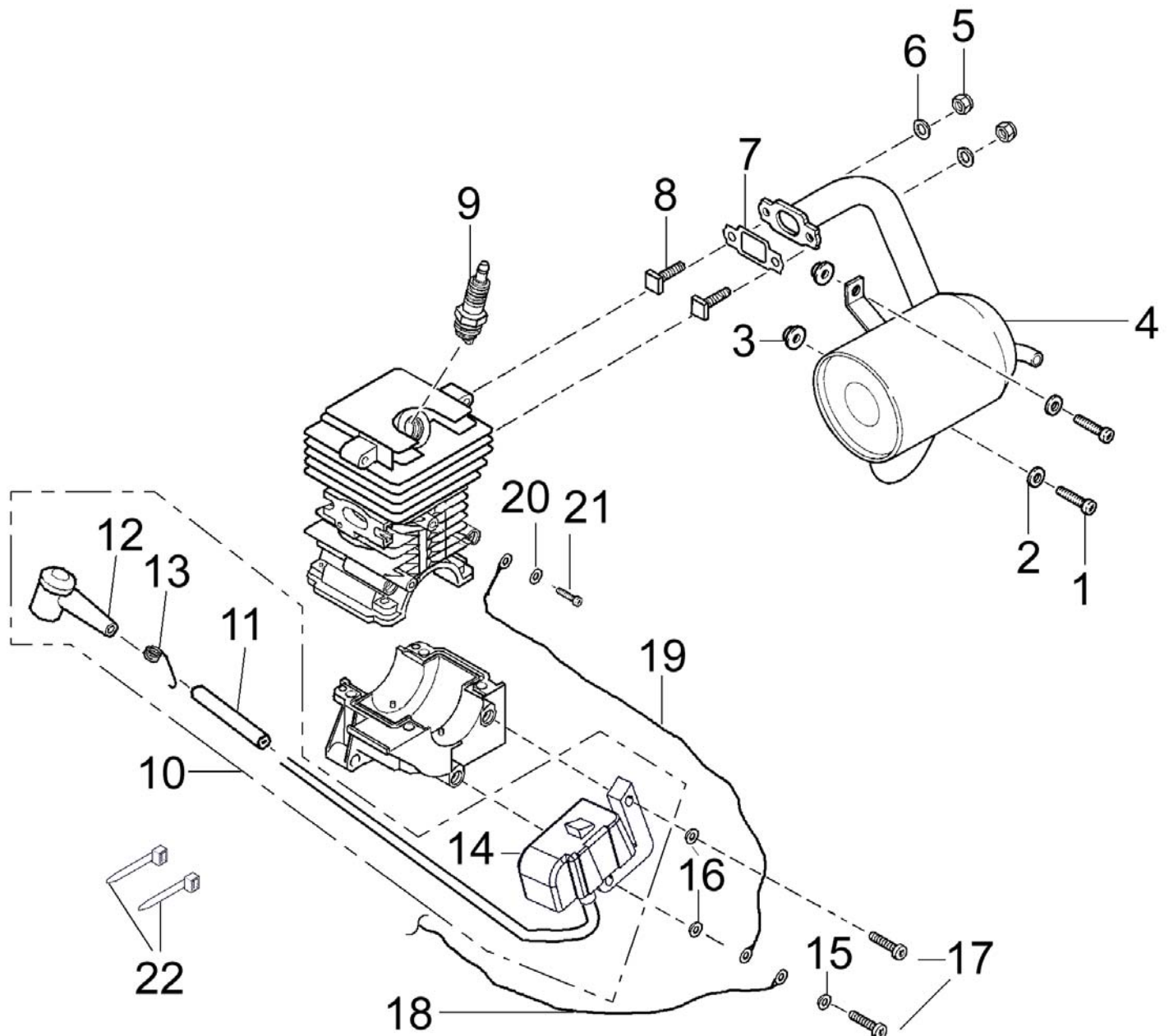

Bild-Nr. Pos.-No. Pos.-No.	Bestell-Nr. Order-No. No. de Cde Ref.-Nr.	Menge Quantity Nombres Cantidad	Gebläsegehäuse	Fan housing	Carter de turbine	Carter de turbina
1	00 18 369	2	Linsenschraube 6x16 mm	Screw	Vis	Tornillo
2	25 00 732	2	Lasche 19,9x2,5 mm	Flap	Collier	Eclisa
3	00 18 348	2	Zylinderschraube M6x25 mm	Screw	Vis	Tornillo
4	40 63 160	1	Profilstück	Profile	Pièce profilée	Perfil
5	21 00 158	1	Gebälsegehäuse 1	Blower housing	Carter de turbine	Carter de turbina
6	00 18 363	12	Linsenschraube 5x20 mm	Screw	Vis	Tornillo
7	20 42 667	1	Klemmplatte	Clamping plate	Plaque de serrage	Placa
8	00 18 362	1	Linsenschraube 5x10 mm	Screw	Vis	Tornillo
9	40 61 908	1	Luftfilterdichtung	Air filter gasket	Joint	Junta de filtro
10	44 00 241	1	Laufrad	Fan wheel	Turbine	Turbina
11	00 34 135	1	Sicherungsscheibe 10	Circlip	Arrêtage	Seguro
12	00 20 104	1	Sechskantmutter M10x1 mm	Nut	Ecrou	Tuerca
13	40 73 107	1	Gebälsegehäuse 2	Blower housing	Carter de turbine	Carter de turbina
14	40 73 154	1	Schutzgitter	Protection screen	Grille	Rejilla
15	00 18 342	2	Zylinderschraube M5x60 mm	Screw	Vis	Tornillo
16	00 20 101	2	Sechskantmutter	Nut	Ecrou	Tuerca

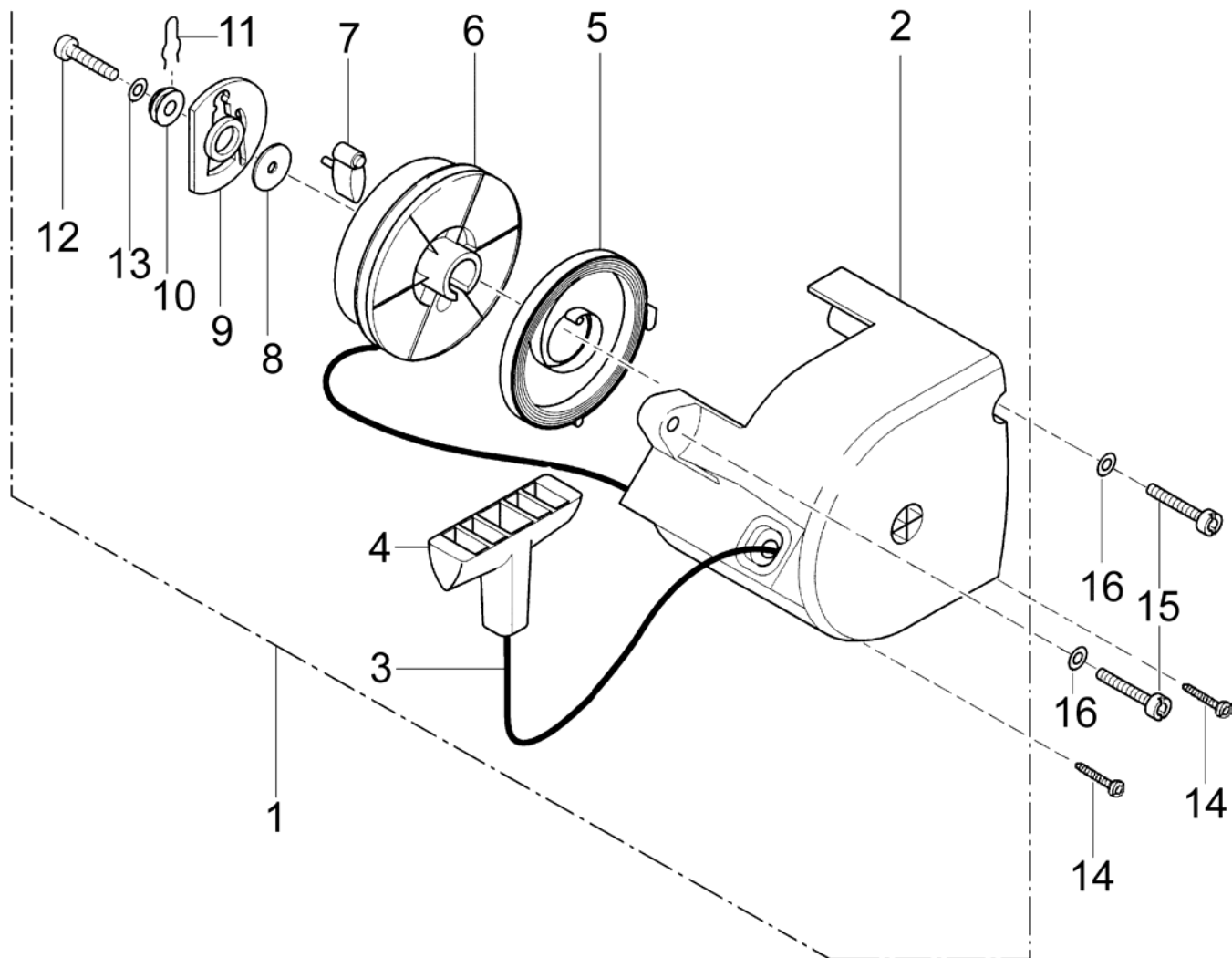

Bild-Nr. Pos.-No. Pos.-No.	Bestell-Nr. Order-No. No. de Cde Ref.-Nr.	Menge Quantity Nombres Cantidad	<b>Luftfilter, Motorabdeckung</b>	<b>Air cleaner, cover cylinder</b>	<b>Filtre à air, capôt cylindre</b>	<b>Filtro de aire, cubierta</b>
1	40 63 160	1	Profilstück	Profile	Pièce profilée	Perfil
2	41 00 109	1	Deckel Ansaugeräusdämpfung, enth. (-> 2 - 6	Exhaust cover incl. (-> 2 - 6	Couvercle échappement y inclus (-> 2 - 6	Cubierta incl. (-> 2 - 6
3	68 00 286	1	Filtermutter M5x12,5 mm	Screw	Ecrou filtre	Tornillo
4	00 55 279	1	Sicherungsring 8x0,8 mm	Safety ring	Bague de sécurité	Anillo de seguridad
5	00 69 721	1	SKS "Choke"	Sticker	Autocollant	Adhesivo
6	40 48 380	1	Filterplatte (-)	Filter plate (-)	Plaque de filtre (-)	Placa de filtro (-)
7	40 73 679	1	Motorabdeckung	Engine cover	Couvercle moteur	Cubierta motor
8	00 18 363	4	Linsenschraube 5x20 mm	Screw	Vis	Tornillo
9	00 69 101	1	SKS "SOLO 450"	Sticker "SOLO 450"	Autocollant "SOLO 450"	Adhesivo "SOLO 450"
10	00 69 716	1	SKS "H-L-T"	Sticker	Autocollant	Adhesivo
11	20 73 503	1	Luftführung	Air guide	Guide d'air	Guia de aire
12	00 18 363	3	Linsenschraube 5x20 mm	Screw	Vis	Tornillo

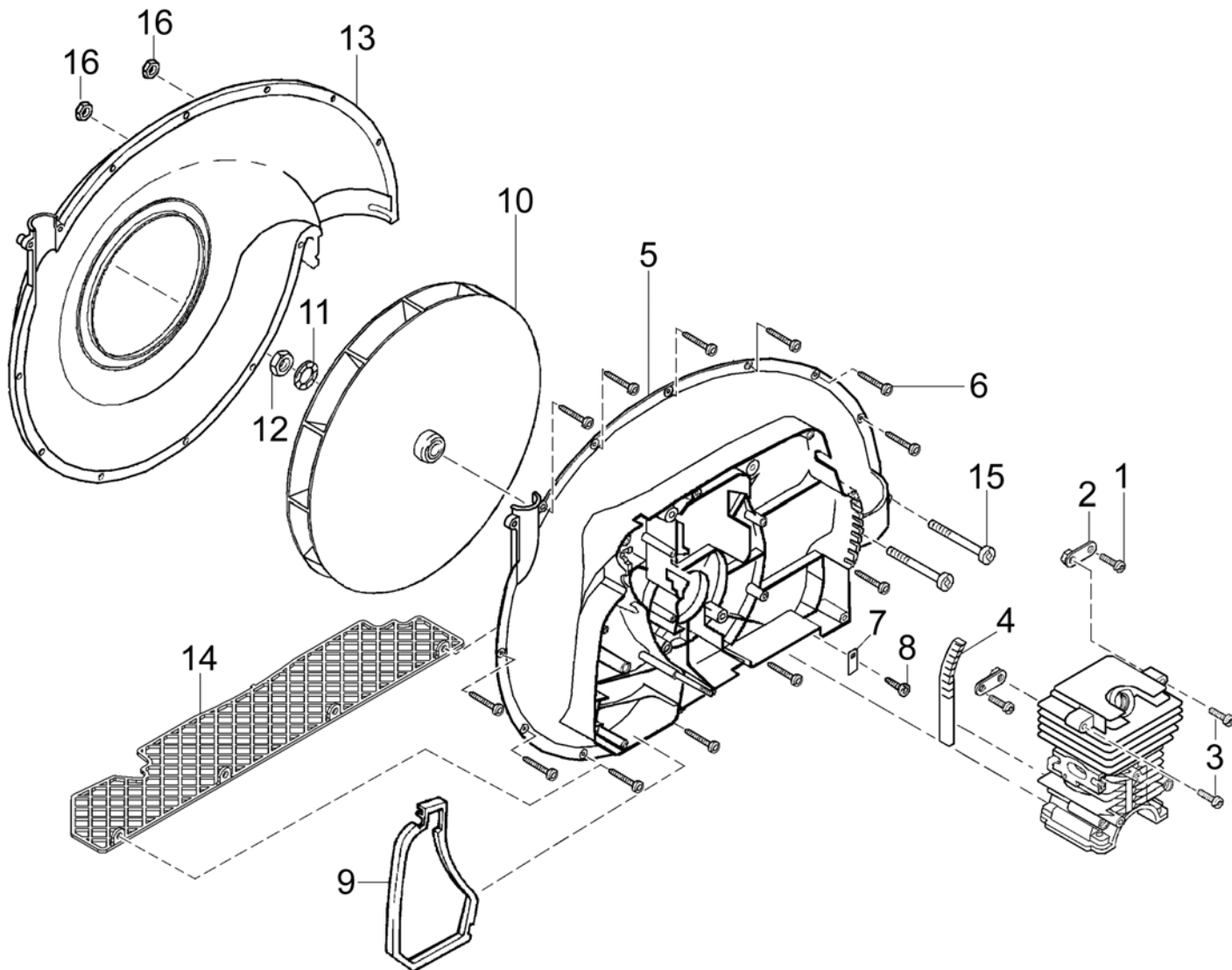

Nuove parti 2005

Bild-Nr. Pos.-No. No.Pos. Pos.-No.	Bestell-Nr. Order-No. No. de Cde Ref.-Nr.	Menge Quantity Nombres Cantidad	Neuer Luftfilter, modifiziertes Lüfterrad (472) ab 2005	New parts 2005 Improved air filter, fan wheel (472)	Nouveaux pièces 2005 Filtre à air, turbine (472)	Nuevo partes 2005 Filtro de aire, turbina (472)
1	40 74 901	1	Ansaugflansch	Inlet flange	Bride	Brida de aspiración
2	00 62 321	1	O-Ring 42 x 2,5 mm	O-ring	Joint torique	Anillo
3	00 62 325	1	O-Ring 21 x 1 mm	O-ring	Joint torique	Anillo
4	00 10 107	2	Zylinderschraube M5 x 50 mm	Screw	Vis	Tornillo
5	40 74 902	1	Choke-Klappenhebel	Choke lever	Levier starter	Juego palanca
6	00 62 263	1	O-Ring 12 x 2,5 mm	O-ring	Joint torique	Anillo
7	40 74 903	1	Luftführung (Vergaserseite)	Air guide (carbureto side)	Guide d'air (part carburateur)	Soporte de aire
8	00 18 361	3	Linsenschraube 5 x 12 mm	Screw	Vis	Tornillo
9	60 63 322	1	Verbindungsschlauch	Connecting hose	Tuyau connexion	Tubo flexible
10	40 74 904	1	Luftführung (Filterseite)	Air guide (filter side)	Guide d'air (part filtre)	Guia de Aire
11	20 48 280	1	Luftfilter	Air filter	Filtre à air	Filtro de aire
12	41 00 109	1	Luftfilterdeckel	Air filter cover	Chapeau filtre	Tapa de filtro
13	20 61 515	1	Vergaserdichtung	Carbureto gasket	Joint de carburateur	Junta carburador
14	50 74 159	1	Kappe	Plug	Capuchon	Casquete
15	44 00 241	1	Lüfterrad (450, 471)	Fan wheel (450, 471)	Turbine (450, 471)	Turbina (450, 471)
15	44 00 277 52	1	Lüfterrad (472)	Fan wheel (472)	Turbine (472)	Turbina (472)

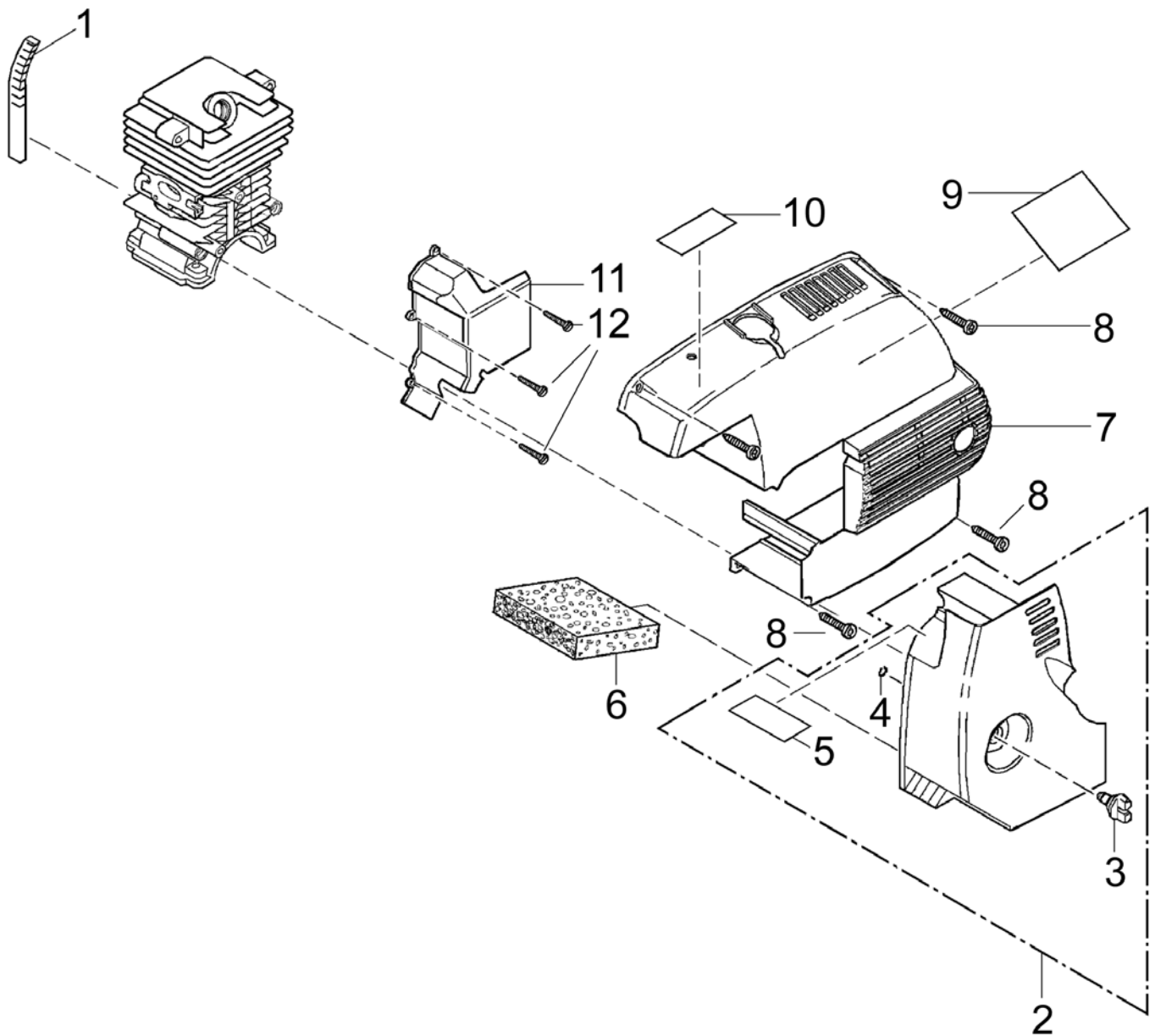
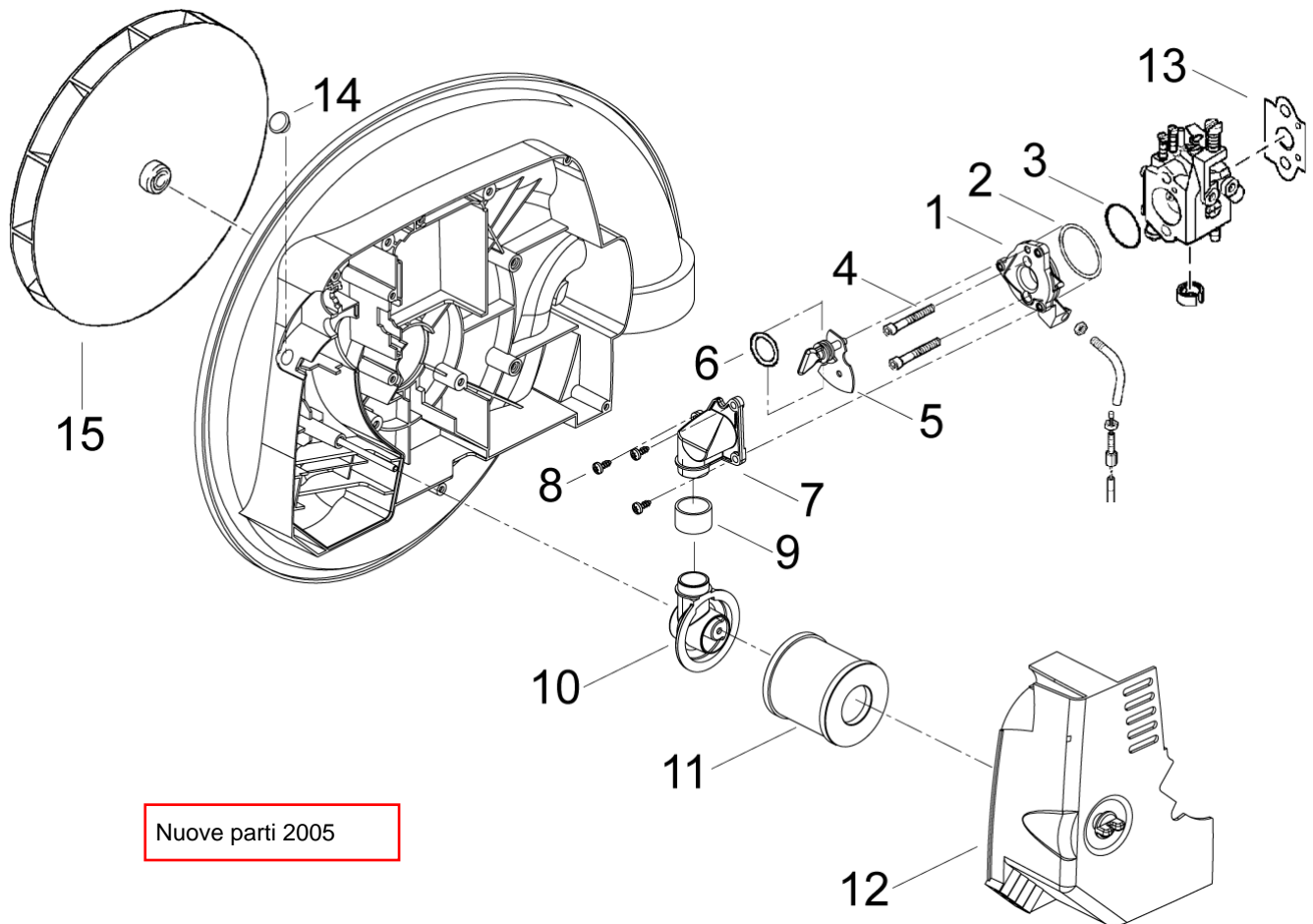
**D**  
**Allgemeine Richtlinien für die Bestellung von Original SOLO Ersatzteilen:**

Voraussetzung für eine reibungslose Erledigung sind folgende Angaben:  
1. Ersatzteil-Bestellnummer  
2. Gewünschte Anzahl  
3. Typenbezeichnung des Geräts  
Diese Ersatzteilliste ist für die Lieferung und Ausstattung von SOLO Erzeugnissen unverbindlich. Im Interesse der technischen Weiterentwicklung bleiben Konstruktionsänderungen vorbehalten.

**GB**  
**General Directions for Ordering Original SOLO Spare Parts:**

For correct and diligent processing of your order, please give the following information:  
1. Spare Part number  
2. Quantity  
3. Model and serial number  
4. Shipping instructions  
Delivery is made in accordance with our general sales and delivery conditions. This spare parts list is non-committal for us with regard to delivery and layout of SOLO products. In favour of technical improvements, design modifications are subject to change without notice.

**F**  
**Directives générales pour les commandes de pièces de rechange d'origine SOLO:**

Il est indispensable de préciser dans toutes les commandes de pièces:  
1. le numéro de référence de la pièce  
2. la quantité  
3. le type de la machine  
4. le mode d'expédition  
Les livraisons sont effectuées dans le cadre de nos conditions générales de vente. Toutes modifications réservées.

**E**  
**Directivas Generales de pedido de la firma SOLO:**

Por adelantado de un arreglo sin dificultades necesitamos siguientes indicaciones:  
1. Número de repuesto  
2. Numero de cantidad  
3. Modelo y número de serial  
4. Instrucción de Envío  
Esta lista de repuestos no es obligatoria para los envíos y/o forma de equipo de los productos SOLO. En el interés del constante desarrollo debemos reservarnos el derecho de cambios.



Bild-Nr. Pos.-No. Pos.-No.	Bestell-Nr. Order-No. No. de Cde Ref.-Nr.	Menge Quantity Nombres Cantidad	Tragegestell	Frame	Châssis	Bastidor
1	40 35 905	1	Rohrbügel 22x1,5	Handle loop	Arceau	Estribo
2	00 61 372	2	Klettband Hacken 60x20 mm	Klettband Hacken	Klettband Hacken	Klettband Hacken
3	40 42 577	2	Spannplatte	Tension plate	Plaque de tension	Placa de tension
4	00 73 396	4	Dämpfungsfeder 3x19x26 mm	Av spring	Ressort amortisseur	Resorte
5	60 43 107	4	Flanschblech	Flange plate	Tôle flange	Chapa
6	00 18 363	8	Linsenschraube 5x20 mm	Screw	Vis	Tornillo
7	40 46 100	2	Spannbügel	Tension bracket	Étrier de tension	Estribo
8	00 18 363	2	Linsenschraube 5x20 mm	Screw	Vis	Tornillo
9	40 74 126	2	Kappe	Cap	Capuchon	Caperuza
10	40 74 275	2	Gurtbefestigung	Strap holder	Porte-bretelle	Soporte
11	40 73 680	1	Rückenplatte	Back plate	Plaque dorsale	Placa
12	00 44 144	5	Steckniet 5,7x18 mm	Cushion rivet	Rivet	Remache
13	00 98 101	1	Rückenkissen	Back cushion	Coussin dorsale	Almohadilla
14	00 18 370	3	Linsenschraube 6x20 mm	Screw	Vis	Tornillo
15	00 18 369	1	Linsenschraube 6x16 mm	Screw	Vis	Tornillo
16	43 00 332	2	Tragegurt enth. (-> 16 - 18)	Shoulder strap incl. (-> 16 - 18)	Bretelle y inclus (-> 16 - 18)	Cinturon portador incl. (-> 16 - 18)
17	40 74 921 25	2	Gurtschließe	Strap clamp	Fermeture bretelle	Cierre
18	43 00 335 25	2	Tragegurt <->	Shoulder strap <->	Bretelle <->	Cinturon portador <->
19	40 74 412	2	Gurthalter, schwarz	Strap holder, black	Porte-bretelle	Hebilla



Bild-Nr. Pos.-No. Pos.-No.	Bestell-Nr. Order-No. No. de Cde Ref.-Nr.	Menge Quantity Nombres Cantidad	Benzintank, Bodenplatte	Fuel tank, bottom plate	Réservoir d'essence, plaque basse	Deposito gasolina, chapa
1	40 73 682	1	Bodenplatte	Bottom plate	Plaque basse	Chapa
2	00 18 274	2	Linsenschraube 5x16	Screw	Vis	Tornillo
3	00 30 102	2	Scheibe 5,3 DIN 9021 A	Washer	Rondelle	Arandela
4	00 18 275	2	Linsenschraube 5x30	Screw	Vis	Tornillo
5	00 61 361	1	Filz	Felt	Feutre	Filtro
6	27 00 351	1	Kraftstoffbehälter enth. (-> 6 - 13)	Fuel tank incl. (-> 6 - 13)	Bouchon d'essence y inclus (-> 6 - 13)	Deposito gasolina incl. (-> 6 - 13)
7	27 00 416	1	Filter-Benzinsucher	Fuel pick-up	Filtre, crépine essence	Filtro gasolina
8	00 73 352	1	Schlauchöse	Grommet	Collier	Manguito de cable
9	60 63 328	1	Kraftstoffschlauch	Fuel hose	Tuyau d'essence	Tubo de gasolina
10	00 73 351	1	Schlauchöse	Grommet	Collier	Manguito de cable
11	80 63 247	1	Tülle	Hose fitting	Ceillet	Manguito de cable
12	27 00 395	1	Tankverschluß, kompl. enth. (-> 12, 13)	Tank cap, compl. incl. (-> 12, 13)	Bouchon réservoir y inclus (-> 12, 13)	Cierre de deposito incl. (-> 12, 13)
13	00 61 280	1	Deckeldichtung 35x45,3x2 mm <->	Lid gasket <->	Joint de couvercle <->	Junta <->
14	00 66 452	2	Stutzen 3x2,5x25	Socket	Raccord de durite	Munon
15	00 64 300	75 mm	Schlauch 3x1,5 mm	Hose	Tuyau	Tubo
16	00 64 300	240 mm	Schlauch 3x1,5 mm	Hose	Tuyau	Tubo
17	27 00 405	1	Entlüftungsstutzen	Ventilation socket	Manchon d'aération	Munon
18	60 63 328	1	Kraftstoffschlauch zum Primer	Fuel hose	Tuyau d'essence	Tubo de gasolina
19	40 35 905	1	Rohrbügel 22x1,5	Handle loop	Arceau	Estribo

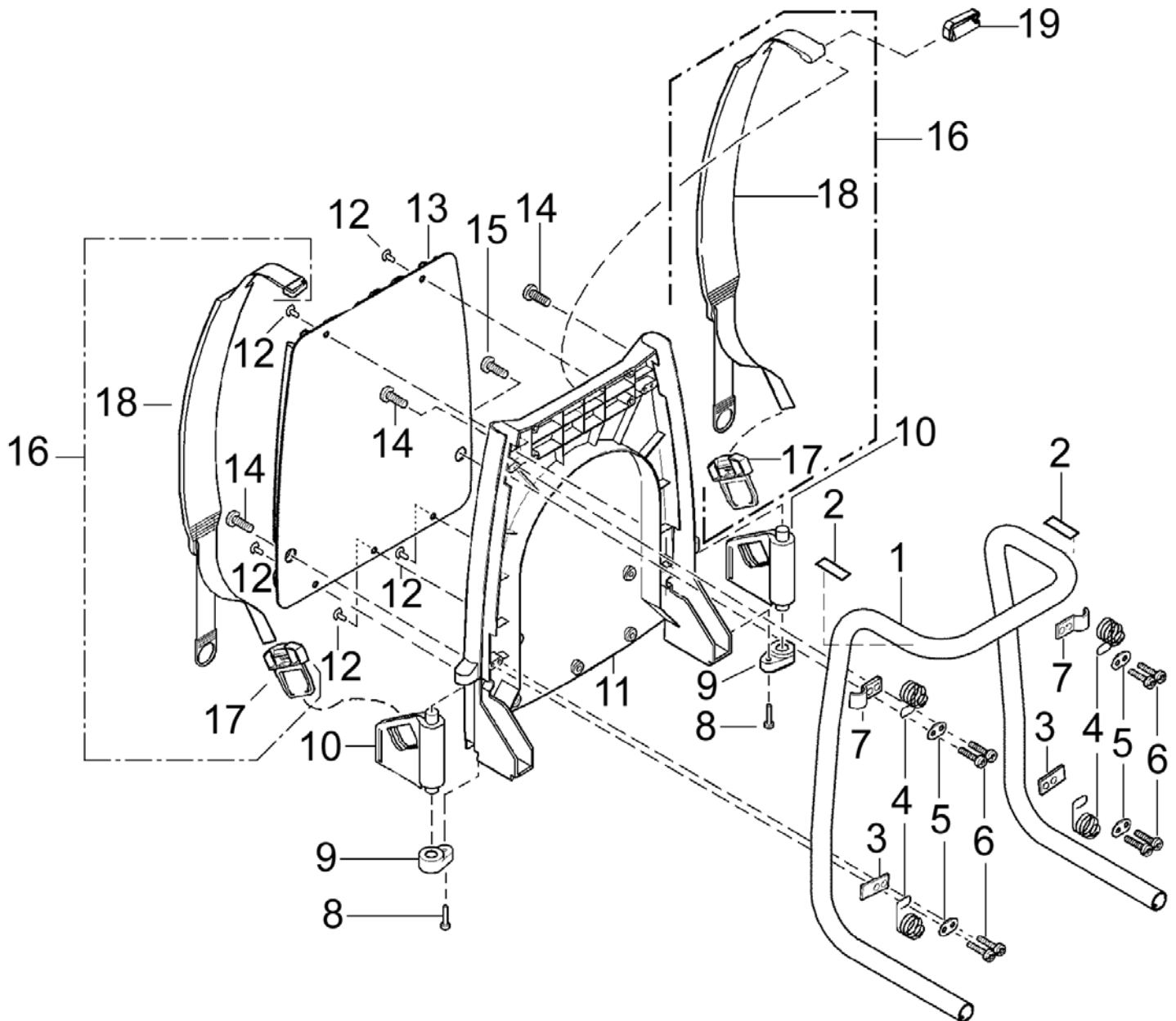

Bild-Nr. Pos.-No. Pos.-No. Pos.-No.	Bestell-Nr. Order-No. No. de Cde Ref.-Nr.	Menge Quantity Nombres Cantidad	Behälter	Tank frame	Support de réservoir	Depósito
1	42 00 104	1	Einfüllkorb mit V2A Sieb	Liquid strainer V2A Sieb	Entonnier V2A Sieb	Cesta de relleno V2A Sieb
1	42 00 105	1	Einfüllkorb mit Kunststoffsieb	Liquid strainer Kunststoffsieb	Entonnier Kunststoffsieb	Cesta de relleno Kunststoffsieb
2	00 64 138	340 mm	PVC-Schlauch 8x2 mm	Hose	Tuyau	Tubo
3	42 00 324	1	Deckel enth. (-> 3 - 4	Tank lid Incl. (-> 3 - 4	Couvercle Y inclus (-> 3 - 4	Tapa del depósito Incl. (-> 3 - 4
4	00 62 331	1	O-Ring 12,4x4,5 mm <-)	Ring <-)	Joint torique <-)	Anillo <-)
5	42 00 322	1	Behälter 12 Liter	Tank frame 12 l	Support de réservoir 12 l	Depósito 12 l
5	42 00 305	1	Behälter 20 Liter	Tank frame 20 l	Support de réservoir 20 l	Depósito 20 l
6	40 74 271	1	Stopfen	Outleg plug	Bouchon	Tapon para Descarga
7	00 62 280	1	O-Ring 30x3 mm	Ring	Joint torique	Anillo
8	40 74 265	1	Schraubkörper	Threaded collar	Ecrou de réservoir	Tapa
9	40 74 282	1	Stopfen	Outleg plug	Bouchon	Tapon para Descarga
10	00 62 280	1	O-Ring 30x3 mm	Ring	Joint torique	Anillo
11	40 74 265	1	Schraubkörper	Threaded collar	Ecrou de réservoir	Tapa
12	00 73 350	1	Drahtschelle	Clamp	Collier	Abrazadera
13	40 63 143	1	Kugelbalg	Siphon	Manchette	Manguito
14	00 63 143	2	Klettband Flauschteil	Klettband Flauschteil	Klettband Flauschteil	Klettband Flauschteil

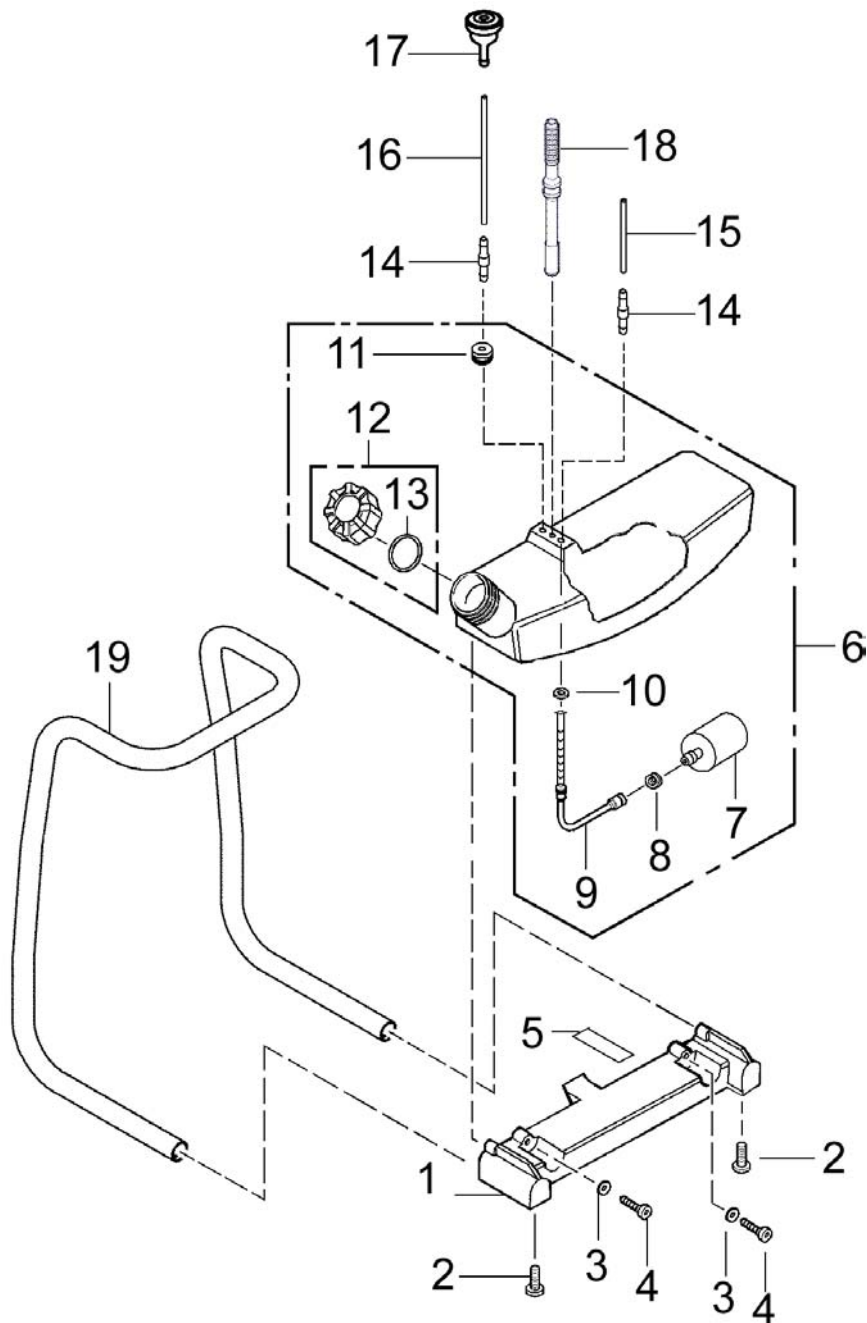

Bild-Nr. Pos.-No. Pos.-No. Pos.-No.	Bestell-Nr. Order-No. No. de Cde Ref.-Nr.	Menge Quantity Nombres Cantidad	Blasrohr, Handgriff	Air Tube, handle	Tube de soufflerie, guidon	Tubo soplador, empuñadura
1	49 00 264	1	Umlenkdüse 54/86 enth. (-> 1, 2	Deflector nozzle incl. (->1, 2	Buse déflectrice y inclus (->1, 2	Tobera incl. (->1, 2
2	40 74 308	1	Umlenkgitter <-)	Deflector screen <-)	Grille déflectrice <-)	Pasador <-)
3	40 74 306	1	Doppelgitter	Double screen	Grille double	Pasador
4	40 74 721	1	Breitstrahlgitter	Diffuser screen	Grille à diff. Large	Pasador
5	40 73 232	1	Weitstrahldüse	Wide-angle nozzle	Buse à diff. Large	Boquilla
6	49 00 293	1	Sprühdüse enth. (-> 6 - 12	Spray nozzle incl. (-> 6 - 12	Buse d'atomisation y inclus (-> 6 - 12	Tobera de pulverización incl. (-> 6 - 12
7	40 73 141	1	Sprühdüse 50/62,5	Spray nozzle	Buse d'atomisation	Tobera de pulverización
8	40 74 251	1	Düsenrohr 6/7x54	Tube	Tube	Tubo
9	00 62 267	1	O-Ring 12x2 mm	Ring	Joint bague	Anillo
10	40 74 165	1	Dosierhülse 1,7/2,5/4/6,5	Dosage sleeve	Douille de dosage	Tobera
11	00 18 328	1	Zylinderschraube M4x25 mm	Screw	Vis	Tornillo cilindrico
12	00 20 106	1	Sechskantmutter M4 <-)	Nut <-)	Écrou <-)	Tuerca <-)
13	44 00 107	1	Blasrohr 63/68,5x590 mm	Tube	Tube	Tubo
14	00 66 399	1	Schelle 68x10 mm, kompl. enth. (-> 14 - 16	Clamp, compl. incl. (-> 14 - 16	Collier, compl. y inclus (-> 14 - 16	Abrazadera, compl. incl. (-> 14 - 16
15	00 11 274	1	Zylinderschraube M5x50 mm	Screw	Vis	Tornillo
16	00 21 257	1	Sechskantmutter M4 <-)	Nut <-)	Écrou <-)	Tuerca <-)
17	40 74 318	1	Kappe	Cap	Capuchon	Caperuza
18	40 71 148	1	Faltenschlauch 92D	Pleated hose	Tuyau pliable	Tubo plegable
19	00 66 130	1	Klemmschelle 83	Clamp	Collier	Abrazadera
20	00 18 275	1	Linsenschraube 5x30 mm	Screw	Vis	Tornillo
21	44 00 109	1	Gebälsekrümmer enth. (-> 21 - 23	Blower elbow incl. (-> 21 - 23	Coude y inclus (-> 21 - 23	Codo incl. (-> 21 - 23
22	00 18 274	4	Linsenschraube 5x16 mm	Screw	Vis	Tornillo
23	40 73 466	1	Abdeckung <-)	Cover <-)	Recouvrement <-)	Cubierta <-)
24	48 00 222	1	Griffhälfte links, kompl.	Grip half left, compl.	Poignée moitié gauche, compl.	Maneta, compl.
25	00 73 408	1	Drehfeder 1x9	Spring	Ressort	Resorte
26	40 73 673	1	Gashebel	Throttle lever	Lever à gaz	Palanca de gas
27	00 55 101	1	Sicherungsscheibe	Safety washer	Rondelle	Arandela
28	40 74 938	1	Griffhälfte, außen	Outer grip half	Poignée ext., moitié	Maneta
29	00 18 356	4	Linsenschraube 4x20 mm	Screw	Vis	Tornillo
30	00 18 357	3	Linsenschraube 4x25 mm	Screw	Vis	Tornillo
31	00 84 477	1	Kurzschlußschalter	Short circuit switch	Bouton marche arrêt	Interruptor
32	28 00 566	1	Bowdenzug Gas	Bowden cable gas	Câble de bowden gaz	Cable de bowden gas
33	00 84 855	1	Massekabel, Kurzschlußkabel	Short-circuit cable	Câble court-circuit	Cable cortocircuito
34	00 64 415 27	1	Wellschlauch 8,5 mm	Hose	Tube	Tubo
35	00 64 138	840 mm	PVC Schlauch 8x2 mm	Hose	Tube	Tubo
36	00 64 138	495 mm	PVC Schlauch 8x2 mm	Hose	Tube	Tubo
37	48 00 214	1	Abstellhahn	Cock	Robinet	Llave
38	00 18 257	2	Linsenschraube 5x25 mm	Screw	Vis	Tornillo

Bestell-Nr. Order-No. No. de Cde Ref.-Nr.	Menge Quantity Nombres Cantidad	Seite Page Page Pagina
00 10 107	1	3
00 10 595	1	3
00 11 274	1	11
00 18 257	2	11
00 18 258	2	5
00 18 274	2	9
00 18 274	4	11
00 18 275	2	9
00 18 275	1	11
00 18 280	1	4
00 18 326	2	4
00 18 328	1	11
00 18 338	2	2
00 18 338	2	3
00 18 338	2	5
00 18 340	6	2
00 18 342	2	6
00 18 348	2	6
00 18 356	4	11
00 18 357	3	11
00 18 362	1	6
00 18 363	2	2
00 18 363	2	4
00 18 363	12	6
00 18 363	4	7
00 18 363	3	7
00 18 363	8	8
00 18 363	2	8
00 18 369	2	6
00 18 369	1	8
00 18 370	3	8
00 18 372	2	2
00 18 384	1	5
00 18 421	2	4
00 20 101	2	6
00 20 104	1	2
00 20 104	1	6
00 20 106	1	11
00 21 235	2	3
00 21 256	2	2
00 21 256	2	3
00 21 257	1	11
00 28 100	2	4
00 30 102	2	9
00 30 135	1	4
00 31 375	2	2
00 31 611	1	5
00 34 135	1	2
00 34 135	1	6
00 34 152	1	5
00 44 144	5	8
00 50 102	2	2
00 52 226	1	2
00 54 220	2	2

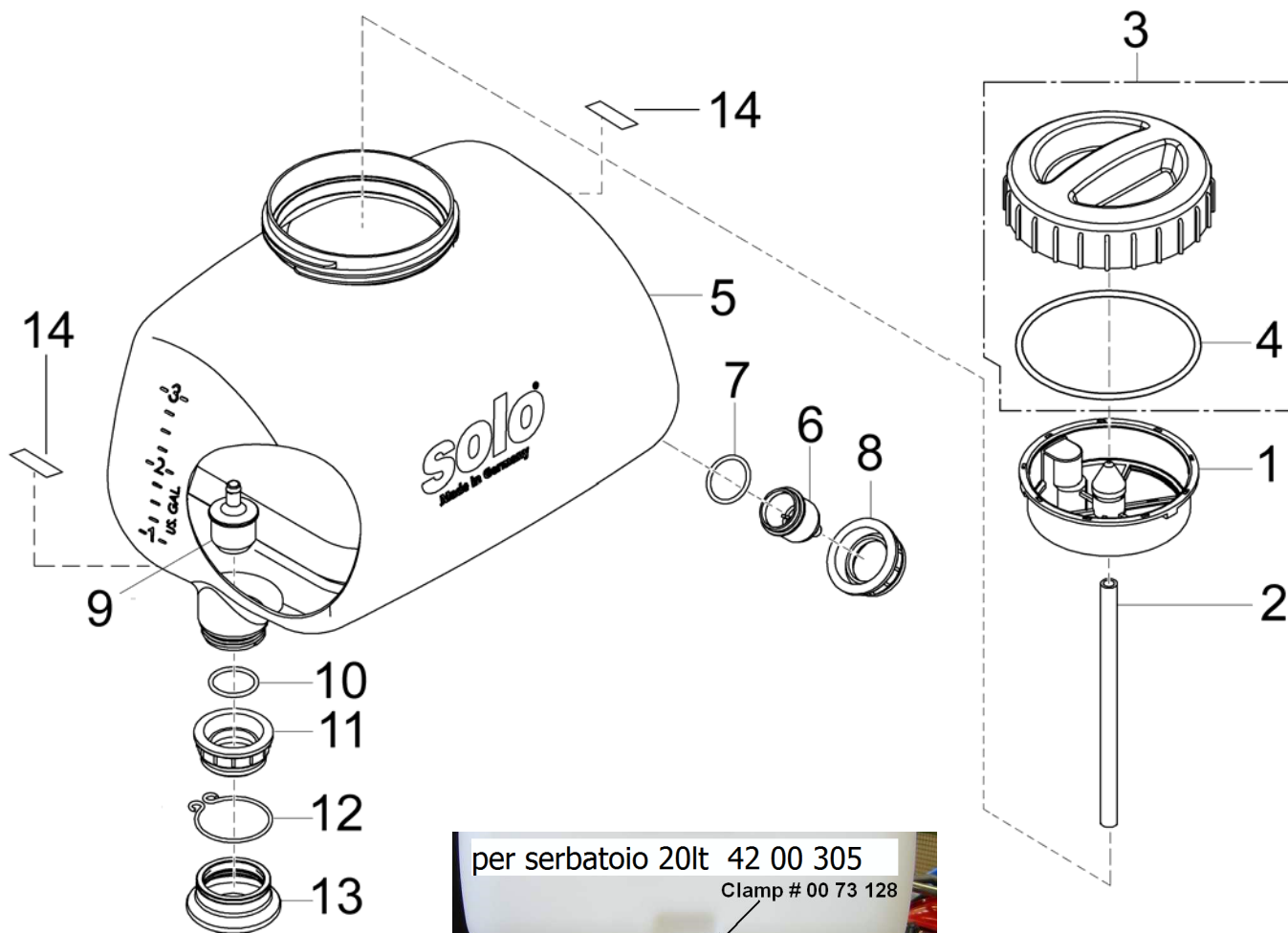
Bestell-Nr. Order-No. No. de Cde Ref.-Nr.	Menge Quantity Nombres Cantidad	Seite Page Page Pagina
00 55 101	1	11
00 55 278	2	2
00 55 279	1	7
00 61 280	1	9
00 61 361	1	9
00 61 372	2	8
00 62 263	1	3
00 62 267	1	11
00 62 280	1	10
00 62 280	1	10
00 62 290	2	2
00 62 321	1	3
00 62 325	1	3
00 62 331	1	10
00 63 143	2	10
00 63 195 25	1	5
00 64 138	340 mm	10
00 64 138	840 mm	11
00 64 138	495 mm	11
00 64 292	200 mm	4
00 64 300	205 mm	3
00 64 300	75 mm	9
00 64 300	240 mm	9
00 64 407	70 mm	3
00 64 415 27	1	11
00 66 130	1	11
00 66 399	1	11
00 66 452	1	3
00 66 452	2	9
00 66 455	2	4
00 69 101	1	7
00 69 716	1	7
00 69 721	1	7
00 72 140	6	2
00 72 143	2	4
00 72 144	2	2
00 72 144	2	3
00 72 144	2	4
00 72 144	2	5
00 72 148	2	4
00 72 161	1	4
00 73 347	1	4
00 73 350	1	10
00 73 351	1	9
00 73 352	1	9
00 73 365	1	5
00 73 396	4	8
00 73 408	1	11
00 75 101	1	2
00 84 477	1	11
00 84 621	1	4
00 84 855	1	4
00 84 855	1	11
00 84 866	1	4

Bestell-Nr. Order-No. No. de Cde Ref.-Nr.	Menge Quantity Nombres Cantidad	Seite Page Page Pagina
00 98 101	1	8
05 10 949	1	3
05 10 982	1	3
05 10 983	1	3
20 00 474	1	2
20 11 112	1	2
20 31 117 25	1	2
20 31 965	1	5
20 42 667	1	6
20 61 103	1	4
20 61 511	1	2
20 61 511	1	3
20 61 515	1	3
20 63 371	1	2
20 73 503	1	7
20 74 295	2	2
20 74 343	1	5
20 74 540	1	2
20 74 540	1	3
20 74 562	2	4
20 74 570	1	5
20 74 774	1	2
20 74 905	1	3
20 74 914	1	3
20 74 915	1	5
20 74 926	1	3
20 74 960	1	3
20 74 977	1	5
21 00 123	1	5
21 00 158	1	6
21 00 653	1	2
22 00 109	1	2
22 00 248	1	2
23 00 203	1	4
23 00 204	1	4
23 00 730	1	2
23 00 730	1	4
23 00 774	1	2
23 00 805	1	3
25 00 732	2	6
25 00 749	1	4
26 00 106	1	5
26 00 284	1	5
27 00 322	1	3
27 00 351	1	9
27 00 395	1	9
27 00 405	1	9
27 00 416	1	9
28 00 566	1	3
28 00 566	1	11
40 35 905	1	8
40 35 905	1	9
40 42 577	2	8
40 42 817	2	2

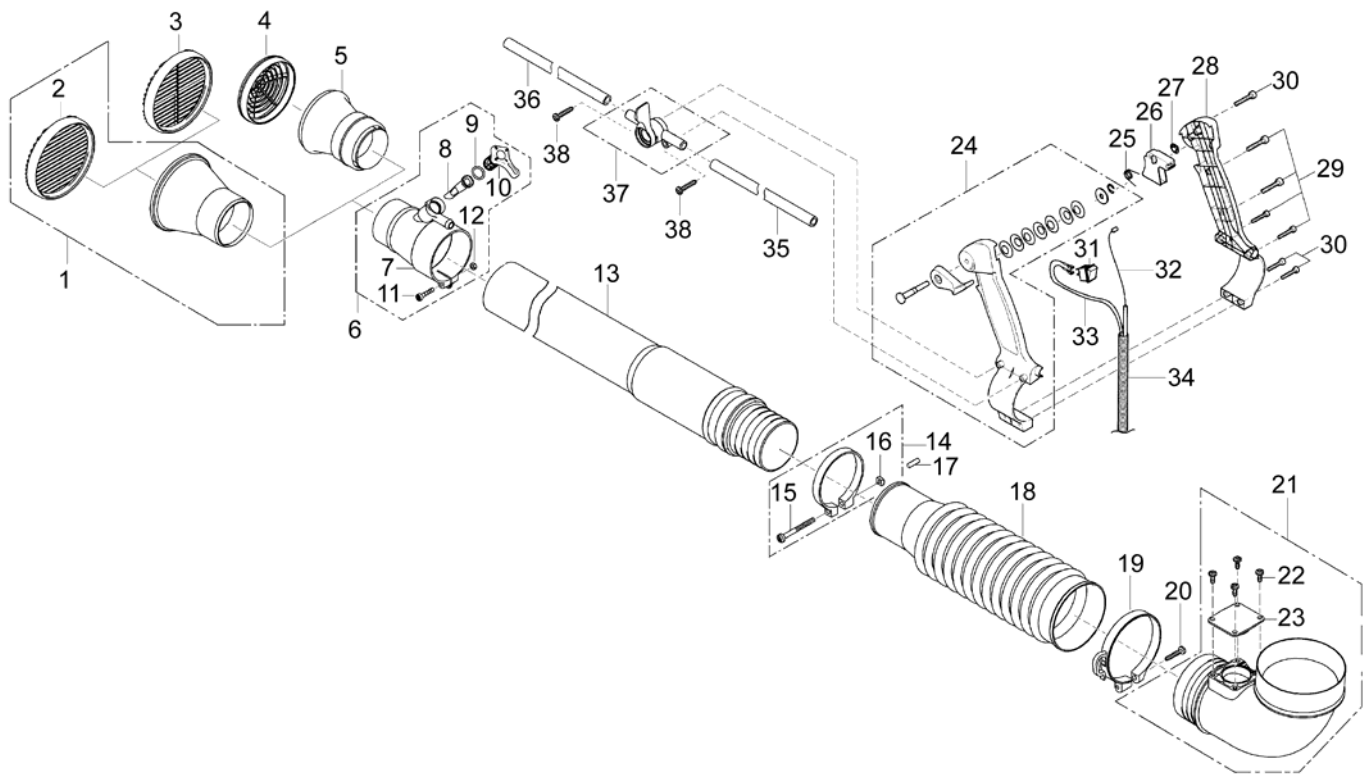
Bestell-Nr. Order-No. No. de Cde Ref.-Nr.	Menge Quantity Nombres Cantidad	Seite Page Page Pagina
40 42 817	2	3
40 43 999	1	2
40 46 100	2	8
40 48 380	1	7
40 61 908	1	6
40 63 143	1	10
40 63 160	1	6
40 63 160	1	7
40 71 148	1	11
40 73 107	1	6
40 73 141	1	11
40 73 154	1	6
40 73 232	1	11
40 73 466	1	11
40 73 673	1	11
40 73 679	1	7
40 73 680	1	8
40 73 682	1	9
40 74 126	2	8
40 74 165	1	11
40 74 251	1	11
40 74 265	1	10
40 74 265	1	10
40 74 271	1	10
40 74 275	2	8
40 74 282	1	10
40 74 306	1	11
40 74 308	1	11
40 74 318	1	11
40 74 412	2	8
40 74 721	1	11
40 74 921 25	2	8
40 74 938	1	11
41 00 109	1	7
42 00 104	1	10
42 00 105	1	10
42 00 305	1	10
42 00 322	1	10
42 00 324	1	10
43 00 332	2	8
43 00 335 25	2	8
44 00 107	1	11
44 00 109	1	11
44 00 241	1	6
48 00 214	1	11
48 00 222	1	11
49 00 264	1	11
49 00 293	1	11
49 00 536	1	3
60 43 107	4	8
60 63 328	1	9
60 63 328	1	9
68 00 286	1	7
80 63 247	1	9

**D**  
**Allgemeine Richtlinien für die Bestellung von Original SOLO Ersatzteilen:**

Voraussetzung für eine reibungslose Erledigung sind folgende Angaben:

1. Ersatzteil-Bestellnummer
2. Gewünschte Anzahl
3. Typenbezeichnung des Geräts

Diese Ersatzteilliste ist für die Lieferung und Ausstattung von SOLO Erzeugnissen unverbindlich. Im Interesse der technischen Weiterentwicklung bleiben Konstruktionsänderungen vorbehalten.

**GB**  
**General Directions for Ordering Original SOLO Spare Parts:**

For correct and diligent processing of your order, please give the following information:

1. Spare Part number
2. Quantity
3. Model and serial number
4. Shipping instructions

Delivery is made in accordance with our general sales and delivery conditions. This spare parts list is non-committal for us with regard to delivery and layout of SOLO products. In favour of technical improvements, design modifications are subject to change without notice.

**F**  
**Directives générales pour les commandes de pièces de rechange d'origine SOLO:**

Il est indispensable de préciser dans toutes les commandes de pièces:

1. le numéro de référence de la pièce
2. la quantité
3. le type de la machine
4. le mode d'expédition

Les livraisons sont effectuées dans le cadre de nos conditions générales de vente. Toutes modifications réservées.

**E**  
**Directivas Generales de pedido de la firma SOLO:**

Por adelantado de un arreglo sin dificultades necesitamos siguientes indicaciones:

1. Número de repuesto
2. Numero de cantidad
3. Modelo y número de serial
4. Instrucción de Envío

Esta lista de repuestos no es obligatoria para los envíos y/o forma de equipo de los productos SOLO. En el interés del constante desarrollo debemos reservarnos el derecho de cambios.