

<p>(D) Ersatzteilliste</p>	<p>Motor-Druckspritze</p>	<p>433</p>	<p>Inhaltsverzeichnis</p>	<p>Seite</p>
			<p>Motor 2</p> <p>Luftfilter, Vergaser, Auspuff 3</p> <p>Zündung und Gaszug 4</p> <p>Benzintank 5</p> <p>Lüfterdeckel, Starter 6</p> <p>Verbindung Kupplung-Pumpe, Gashebel 7</p> <p>Pumpe 8</p> <p>Tragegestell, Behälter, Tragegurt 10</p> <p>Spritzrohr 11</p> <p>Ersatzteile 12</p> <p>Bestell-Richtlinien 12</p>	
<p>(GB) Spare parts list</p>	<p>Motor-Sprayer</p>	<p>433</p>	<p>Table of contents</p>	<p>Page</p>
			<p>Engine 2</p> <p>Air filter, carburetor, exhaust 3</p> <p>Ignition and Throttle Cable 4</p> <p>Fuel tank 5</p> <p>Fan cover, recoil starter 6</p> <p>Combination clutch-pump, throttle lever 7</p> <p>Pump 8</p> <p>Carrying frame, tank, Carrying strap 10</p> <p>Spray wand 11</p> <p>Spare Parts 12</p> <p>Directions for Ordering 12</p>	
<p>(F) Liste de pièces de rechange</p>	<p>Pulvérisateur à moteur</p>	<p>433</p>	<p>Table des matières</p>	<p>Page</p>
			<p>Moteur 2</p> <p>Filtre à air, carburateur, échappement 3</p> <p>Allumage et câble accélérateur 4</p> <p>Réservoir à essence 5</p> <p>Capuchon de ventilateur, lanceur 6</p> <p>Connexion embrayage-pompe, accélérateur 7</p> <p>Pompe 8</p> <p>Cadre porteur, réservoir, bretelle 10</p> <p>Tube de pulvérisation 11</p> <p>Pièces de rechange 12</p> <p>Directives pour les commandes 12</p>	
<p>(E) Lista de piezas de recambio</p>	<p>Pulverizador motorizado</p>	<p>433</p>	<p>Indice</p>	<p>Página</p>
			<p>Motor 2</p> <p>Filtro de aire, carburador, escape 3</p> <p>Encendido y cable bowden 4</p> <p>Deposito 5</p> <p>Cubierta, arranque 6</p> <p>Conexión embrague-bomba, palanca gas 7</p> <p>Bomba 8</p> <p>Bastidor, deposito, cinturon portador 10</p> <p>Tubo 11</p> <p>Piezas de recambio 12</p> <p>Directivas de pedido 12</p>	

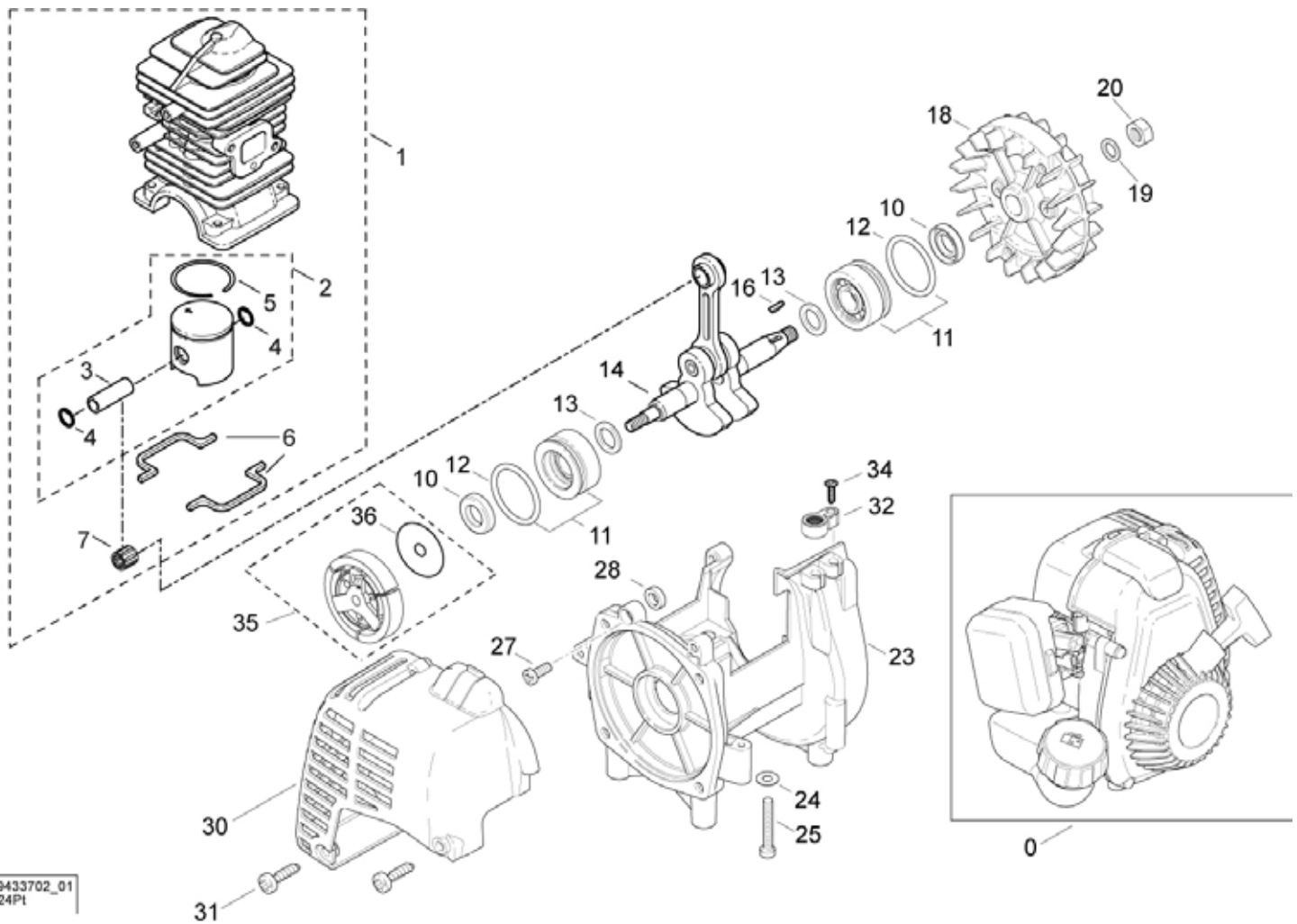

9433702_01
24PI

Bild-Nr. Pos.-No. No.Pos. Pos.-No..	Bestell-Nr. Order-No. No. de Cde Ref.-Nr.	Menge Quantity Nombres Cantidad	Motor, Kurbelwelle	Engine, crankshaft	Moteur, villebrequin	Motor, cigüñeal
0	20 00 643	1	SOLO 2-Takt-Motor 25 cm ³	Engine	Moteur 2-temps 25 cm ³	Motor
1	22 00 160	1	Zylinder + Kolben, Reparatursatz enth.: (-> 1 - 7	Cylinder + piston, repair kit incl. (-> 1 - 7	Cylindre + piston, kit de réparation y inclus (-> 1 - 7	Cilindro + piston, juego de reparacion incl. (-> 1 - 7
2	22 00 162	1	Kolben Ø 33 mm enth. (-> 2 - 5	Piston incl. (-> 2 - 5	Piston y inclus (-> 2 - 5	Piston incl. (-> 2 - 5
3	20 31 902 25	1	Kolbenbolzen 9/6x26 mm	Piston pin	Axe de piston	Perno de embolo
4	00 55 278	2	Sicherungsring 9x0,8 mm	Circlip	Arrêt axe de piston	Anillo de seguridad
5	20 48 377	1	Kolbenring 33x1,5 mm <-)	Piston ring <-)	Segment de piston <-)	Anillo de piston <-)
6	20 63 372	2	Dichtungsteil Kurbelgehäuse	Sealing	Joint carter moteur	Junta
7	00 52 226	1	Nadelhülse 9x13x12,5 mm <-)	Needle sleeve <-)	Douille <-)	Casquillo <-)
10	00 54 258	2	Wellendichtring 12x22x5mm	Oil seal	Joint d'arbre	Reten
11	21 00 121 25	2	Lagerhülse 12x34,17x15,5 mm enth. (-> 11, 12	Sleeve incl. (-> 11, 12	Douille y inclus (-> 11, 12	Casquillo incl. (-> 11, 12
12	00 62 335	2	O-Ring 27x3 mm <-)	O-ring <-)	Joint torique <-)	Anillo <-)
13	00 31 258	2	Scheibe 12x18x1,8 mm	Washer	Rondelle	Arandela
14	22 00 304 52	1	Kurbelwelle	Crankshaft	Vilebrequin	Cigüñeal
16	00 75 100	1	Scheibenfeder 2x3,7 mm	Spring	Clavette	Resorte
18	24 00 311	1	Lüfferrad	Fan wheel	Turbine	Turbina
19	00 72 176	1	Scheibe 8,2x20x1 mm	Washer	Rondelle	Arandela
20	00 21 258	1	Sechskantmutter M8	Hex. nut	Ecrou	Tuerca
23	21 00 122	1	Kurbelgehäuse	Crankcase	Carter moteur	Carter cigüñeal
24	00 72 140	4	Scheibe 5,2x12x0,5 mm	Washer	Rondelle	Arandela
25	00 18 399	4	Zylinderschraube M5x35 mm	F.H. screw	Vis	Tornillo
27	00 18 326	1	Zylinderschraube M4x16 mm	F.H. screw	Vis	Tornillo
28	20 74 562	1	Isolierelement	Insulating element	Élément d'isolation	Elemento aislante
30	40 73 127	1	Abdeckhaube	Cover	Capot	Cubierta
31	00 18 274	2	Linsenschraube 5x16 mm	Screw	Vis	Tornillo
32	20 74 895	1	Klemme	Clamp	Collier	Abrazadera
34	00 18 257	1	Linsenschraube 5x25 mm	Screw	Vis	Tornillo
35	35 00 4651	1	Kupplung enth. (-> 35, 36	Clutch incl. (-> 35, 36	Embrayage y inclus (-> 35, 36	Embrague incl. (-> 35, 36
36	00 31 626	1	Scheibe 8,1x32x1 mm <-)	Washer <-)	Rondelle <-)	Arandela <-)

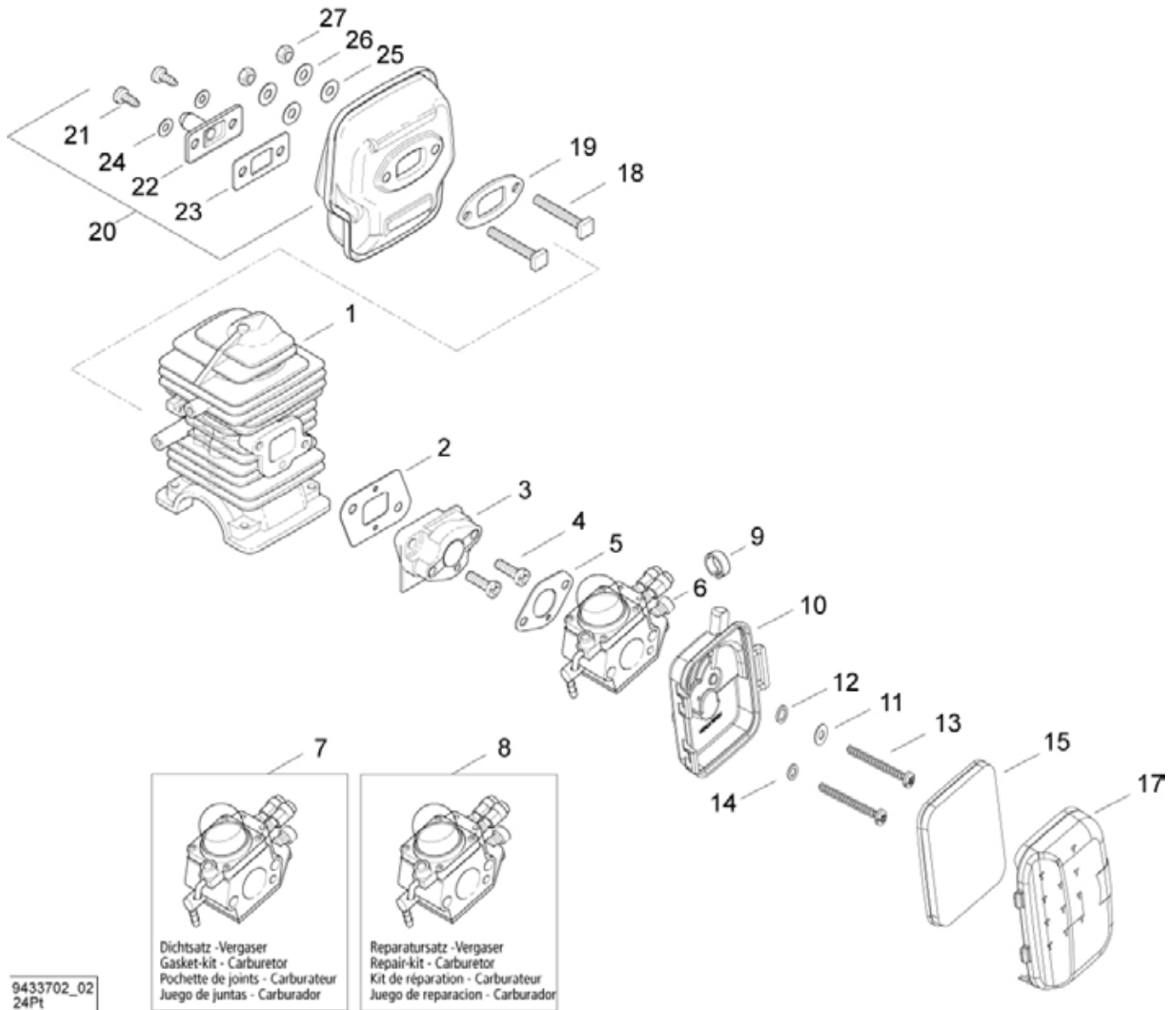

9433702_02
24Pt

Bild-Nr. Pos.-No. No.Pos. Pos.-No..	Bestell-Nr. Order-No. No. de Cde Ref.-Nr.	Menge Quantity Nombres Cantidad	Luftfilter, Vergaser, Auspuff	Air filter, carburetor, exhaust	Filtre à air, carbureteur, échappement	Filtro de aire, carbureador, escape
1	20 11 819	1	Nikasilzylinder Ø 33,00 mm	Cylinder	Cylindre	Cilindro
2	20 61 518	1	Vergaserstutzendichtung	Manifold gasket	Joint de bride	Junta de brida
3	20 74 111	1	Ansaugstutzen	Socket	Bride d'aspiration	Brida
4	00 18 337	2	Zylinderschraube M5x20 mm	F.H. screw	Vis	Tornillo
5	20 61 464	1	Vergaserdichtung	Carburetor gasket	Joint de carburateur	Junta carburador
6	23 00 726 10	1	Vergaser mit Primer	Carburetor w.primar	Carburateur	Carburador
7	05 10 985	1	Dichtsatz-Vergaser	Gasket kit	Jeu de joints	Juego de juntas
8	05 10 984	1	Reparatursatz-Vergaser	Repair kit	Jeu de réparation	Juego rep.
9	20 74 600	1	Haltering	Ring	Bague de retient	Anillo
10	25 00 811	1	Luftfiltergehäuse Unterteil	Filter housing	Carter filtre	Carter de filtro
11	00 61 360	1	Scheibe 6,8x10x1,2 mm	Washer	Rondelle	Arandela
12	00 72 140	1	Scheibe 5,2x12x0,5 mm	Washer	Rondelle	Arandela
13	00 18 429	2	Linsenschraube 5x50 mm	Screw	Vis	Tornillo
14	00 34 100	1	Sicherungsscheibe	Safety washer	Rondelle de sécurité	Arandela seguridad
15	25 00 816	1	Filterplatte	Filterplate	Plaque filtre	Chapa filtro
17	40 73 442	1	Luftfiltergehäuse Oberteil bedruckt	Filter lid	Chapeau filtre	Tapa de filtro
18	00 18 365	2	Vierkantschraube M5x40 mm	Square nut	Ecrou	Tuerca
19	20 61 197	1	Auspuffdichtung	Exhaust gasket	Joint d'échappement	Junta escape
20	25 00 104	1	Auspuff enth. (-> 20 - 24	Exhaust incl. (-> 20 - 24	Echappement y inclus (-> 20 - 24	Escape i ncl. (-> 20 - 24
21	00 10 564	2	Linsenschraube 4x10 mm	Screw	Vis	Tornillo
22	25 00 654	1	Austrittsblech	Plate	Tôle de sortie	Chapa
23	20 61 142	1	Dichtung	Gasket	Joint	Junta
24	00 34 156	2	Federring 4 mm (-)	Spring ring (-)	Rondelle grover (-)	Anillo elastico (-)
25	00 72 144	2	Sicherungsscheibe	Safety washer	Rondelle de sécurité	Arandela seguridad
26	00 72 140	2	Scheibe 5,2x12x0,5 mm	Washer	Rondelle	Arandela
27	00 28 137	2	Sechskantmutter M5	Hex. nut	Ecrou	Tuerca

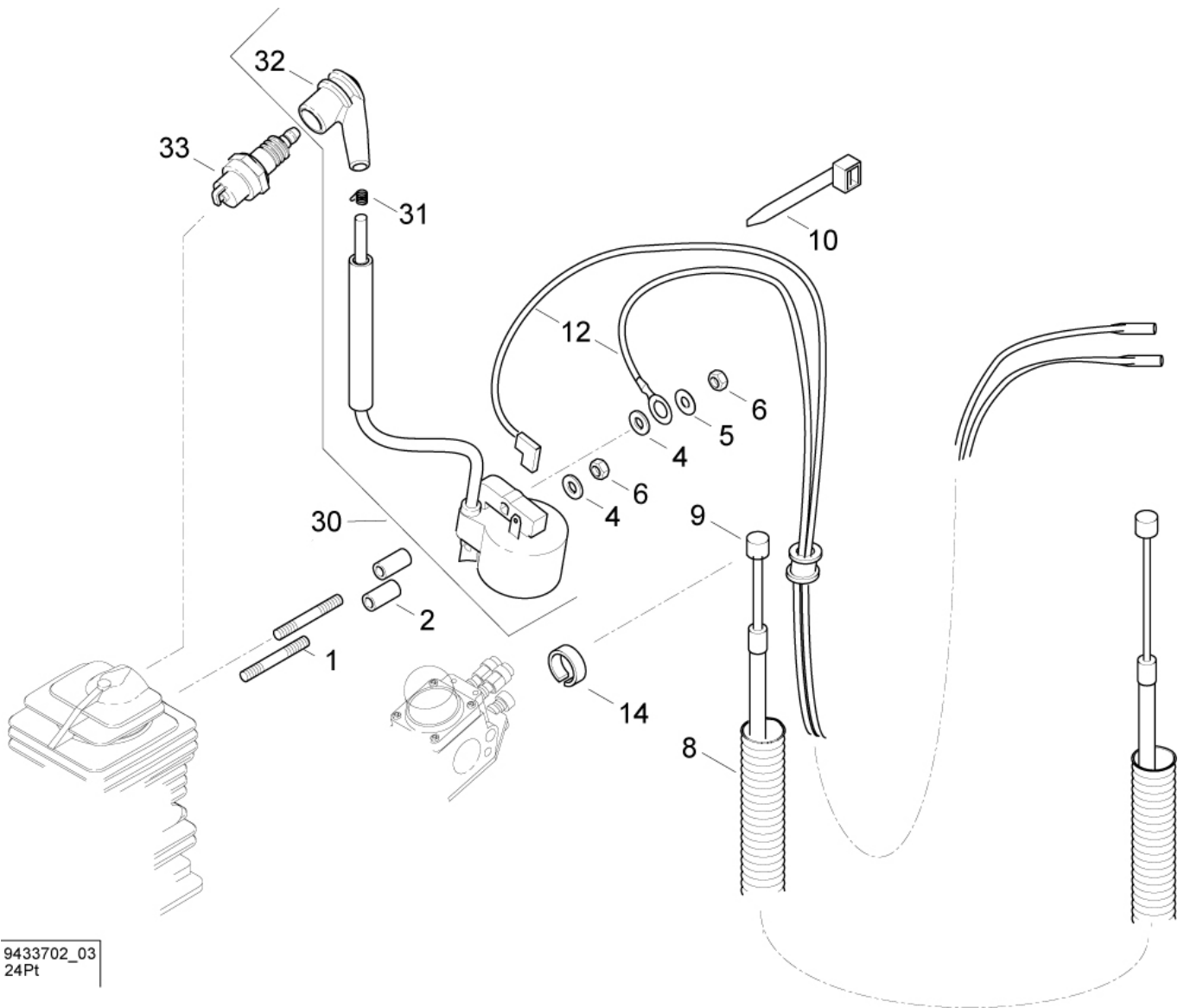

9433702_03
24Pt

Bild-Nr. Pos.-No. Pos.-No.	Bestell-Nr. Order-No. No. de Cde Ref.-Nr.	Menge Quantity Nombres Cantidad	Zündung und Gaszug	Ignition and Throttle Cable	Allumage et câble accélérateur	Encendido y cable
1	00 15 300	2	Stiftschraube M4x30 mm	Stud screw	Goujon	Tornillo
2	00 33 401	2	Hülse 8x4,4x16 mm	Sleeve	Douille	Casquillo
4	00 72 148	2	Sicherungsscheibe	Safety washer	Rondelle	Arandela
5	00 30 101	1	Scheibe 4,3	Washer	Rondelle	Arandela
6	00 28 118	2	Sechskantmutter M4	Hex. nut	Ecrou	Tuerca
8	00 64 415 27	470 mm	Schlauch 8,5	Hose	Tuyau	Tubo
9	28 00 593	1	Bowdenzug Gas	Throttle cable	Câble des gaz	Cable bowden
10	00 66 455	1	Kabelband 98x2,5mm	Cable band	Frein de câble	Cinta
12	00 84 889	1	Kabel Masse/Kurzschluss.	Ground cable	Câble de masse	Cable de masa
14	20 74 600	1	Haltering	Ring	Bague de retient	Anillo
30	23 00 489	1	Zündmodul enth. (-> 30-32)	Ignition coil incl. (-> 30-32)	Volant électronique inclus: (-> 30-32)	Bobina incl. (-> 30-32)
31	00 73 360	1	Kontaktfeder	Contact spring	Ressort de contact	Resorte
32	00 84 621	1	Zündkerzenstecker <-)	Spark plug cover <-)	Capuchon de bougie <-)	Tapa de bujia <-)
33	23 00 730	1	Zündkerze WSR6F 200	Spark plug	Bougie	Bujia

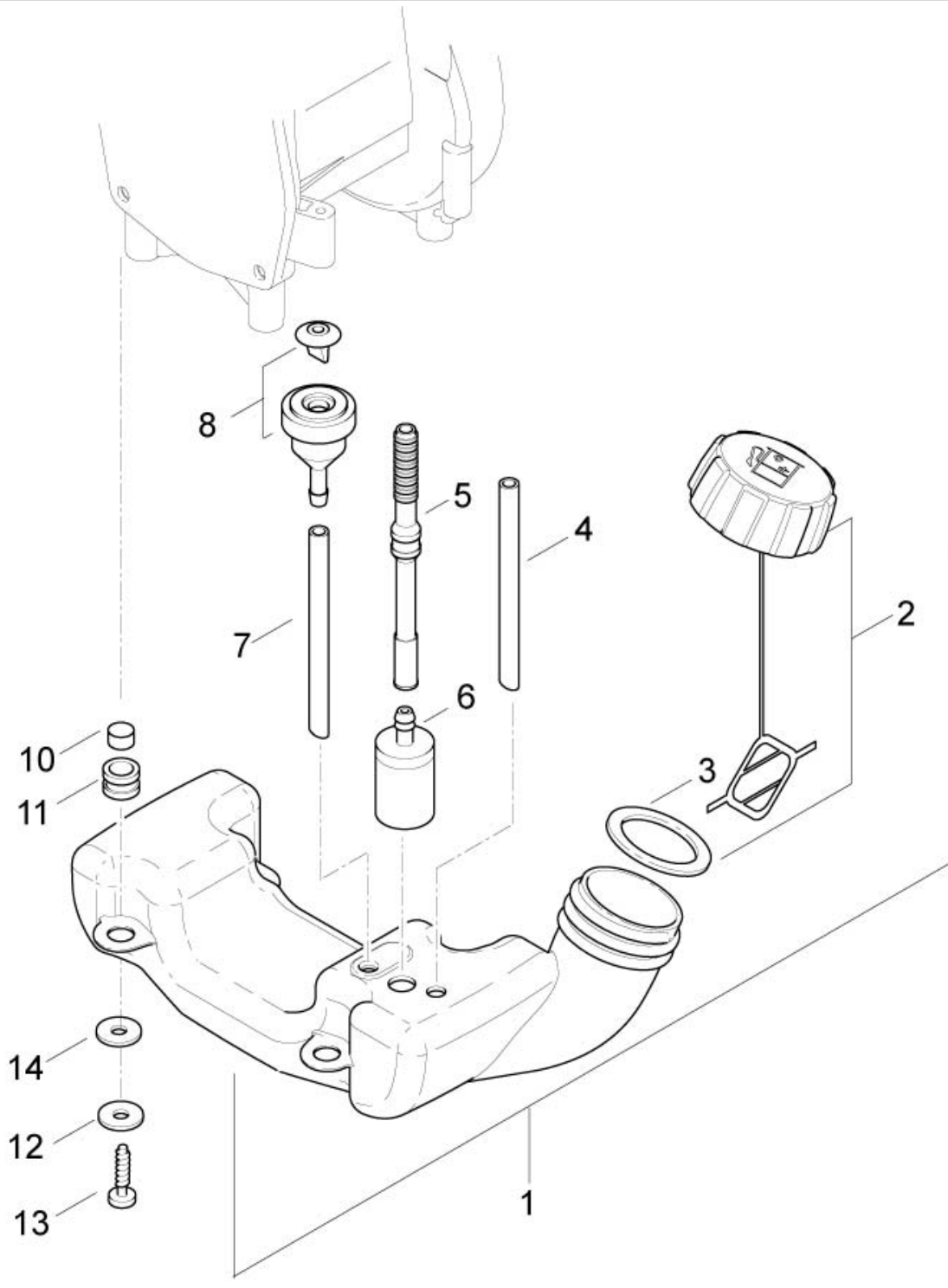

9433702_04
24Pt

Bild-Nr. Pos.-No. Pos.-No.	Bestell-Nr. Order-No. No. de Cde Ref.-Nr.	Menge Quantity Nombres Cantidad	Benzintank	Fuel tank	Réservoir à essence	Deposito
1	27 00 264	1	Benzintank enth. (-> 1-11)	Fuel tank incl. (-> 1-11)	Réservoir à essence y inclus: (-> 1-11)	Deposito incl. (-> 1-11)
2	27 00 187	1	Tankverschluss enth. (-> 2, 3)	Tank lid incl. (-> 2, 3)	Bouchon de réservoir y inclus: (-> 2, 3)	Cierre de deposito incl. (-> 2, 3)
3	00 62 345	1	O-Ring 29x4 mm <-)	O-ring <-)	Joint torique <-)	Anillo <-)
4	00 64 420	1	Schlauch 3x1,5x95mm Primerrücklauf	Hose	Tuyau	Tubo
5	60 63 341	1	Schlauch 3x178 mm Kraftstoff	Fuel hose	Tuyau	Tubo
6	27 00 135	1	Filter Benzinsucher	Fuel pick-up	Crépine d'essence	Filtro
7	00 64 420	1	Schlauch 3x1,5x95 mm Entlüftung	Ventilation hose	Tuyau d'aération	Tubo
8	27 00 430	1	Entlüftungsstutzen	Ventilation socket	Manchon d'aération	Munon
10	20 74 141	4	Distanzhülse	Sleeve	Douille	Casquillo
11	00 94 197	4	Dämpfungsgummi <-)	AV element <-)	Amortisseur <-)	Elemento AV <-)
12	00 31 494	4	Scheibe 5,3 mm	Washer	Rondelle	Arandela
13	00 18 275	4	Linsenschraube 5x30 mm	Screw	Vis	Tornillo
14	00 72 144	4	Sicherungsscheibe	Safety washer	Rondelle de sécurité	Arandela

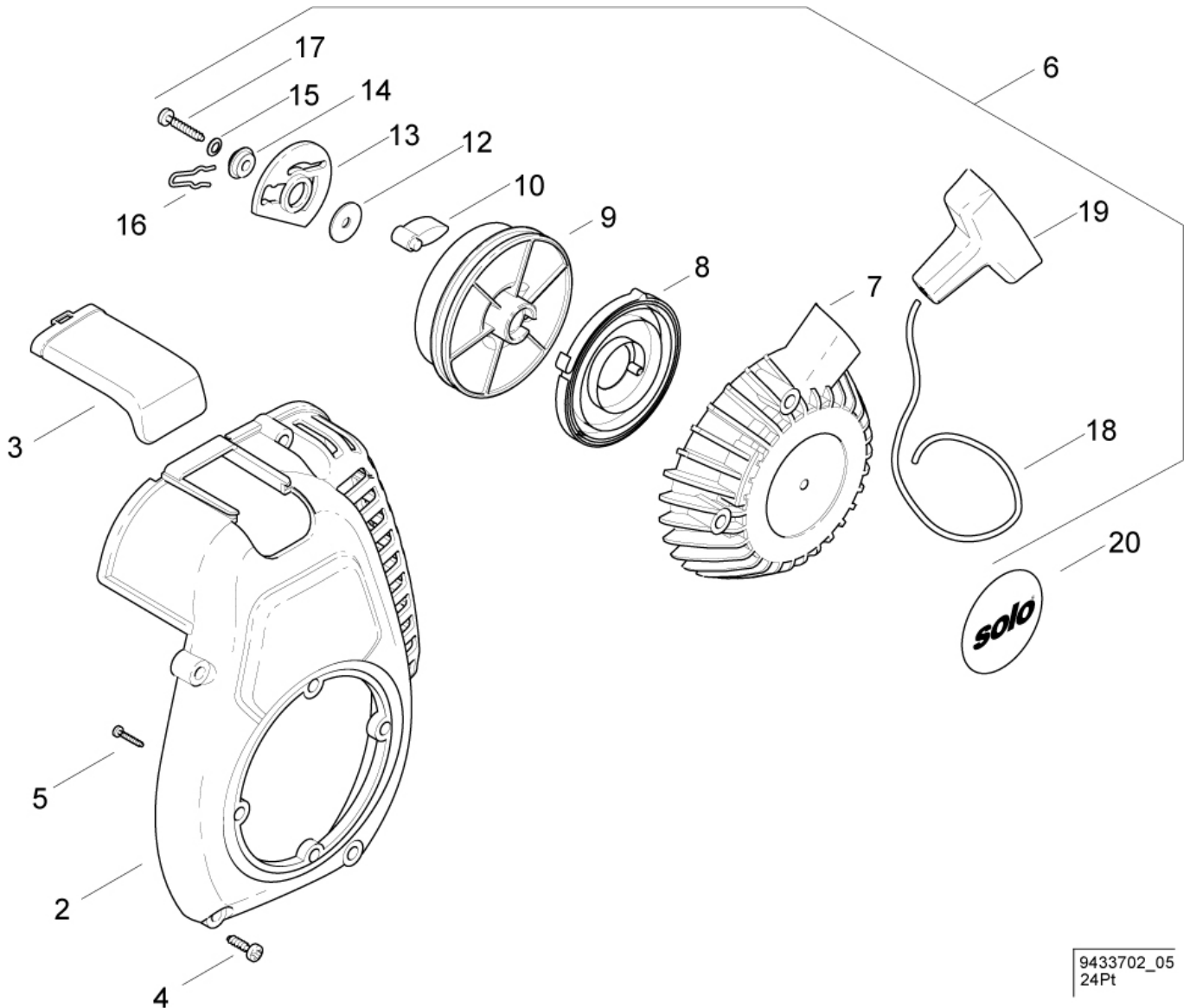

9433702_05
24Pt

Bild-Nr. Pos.-No. Pos.-No. Pos.-No.	Bestell-Nr. Order-No. No. de Cde Ref.-Nr.	Menge Quantity Nombres Cantidad	Lüfterdeckel, Starter	Fan cover, recoil starter	Capuchon de ventilateur, lanceur	Cubierta, arranque
2	40 73 131	1	Lüfterdeckel ohne Starter	Fan cover w/o starter	Capuchon sans carter lanceur	Cubierta sin arranque
3	40 73 128	1	Zündkerzenabdeckung	Spark plug cover	Capuchon de bougie	Tapa de bujia
4	00 18 363	6	Linsenschraube 5x20 mm	Screw	Vis	Tornillo
5	00 18 354	4	Linsenschraube 4x12 mm	Screw	Vis	Tornillo
6	26 00 140	1	Starter-Universal enth. (-> 6-19)	Starter incl. (-> 6-19)	Lanceur y inclus: (-> 6-19)	Arranque incl. (-> 6-19)
7	21 00 126	1	Startergehäuse	Starter housing	Carter lanceur	Caja de arranque
8	26 00 284	1	Federkassette	Spring cassette	Cassette de ressort	Cassette
9	20 74 915	1	Seilrolle	Rope pulley	Poulie de câble	Roldana
10	20 74 343	1	Starterklinke	Pawl	Cliquet de lanceur	Trinquete
12	00 31 611	1	Scheibe 4,3x15x1mm	Washer	Rondelle	Arandela
13	20 74 977	1	Kulisse rot	Template	Coulisse	Colisa
14	20 31 965	1	Distanzstück 4,3x12,5x5 mm	Spacer	Pièce d'écartement	Espaciador
15	00 34 152	1	Sicherungsscheibe	Safety washer	Rondelle de sécurité	Arandela
16	00 73 365	1	Federstecker	Pin	Goupille beta	Clavija
17	00 10 519	1	Zylinderblechschraube. 3,5x22 mm	Screw	Vis	Tornillo
18	00 63 195 25	1	Starterseil 3x1050 mm	Starter rope	Câble lanceur	Cuerda de arranque
19	20 74 570	1	Startergriff (->)	Starter grip (->)	Poignée lanceur (->)	Empunadura (->)
20	00 69 890	1	Sks. Solo	Decal	Autocollant Solo	Adhesivo

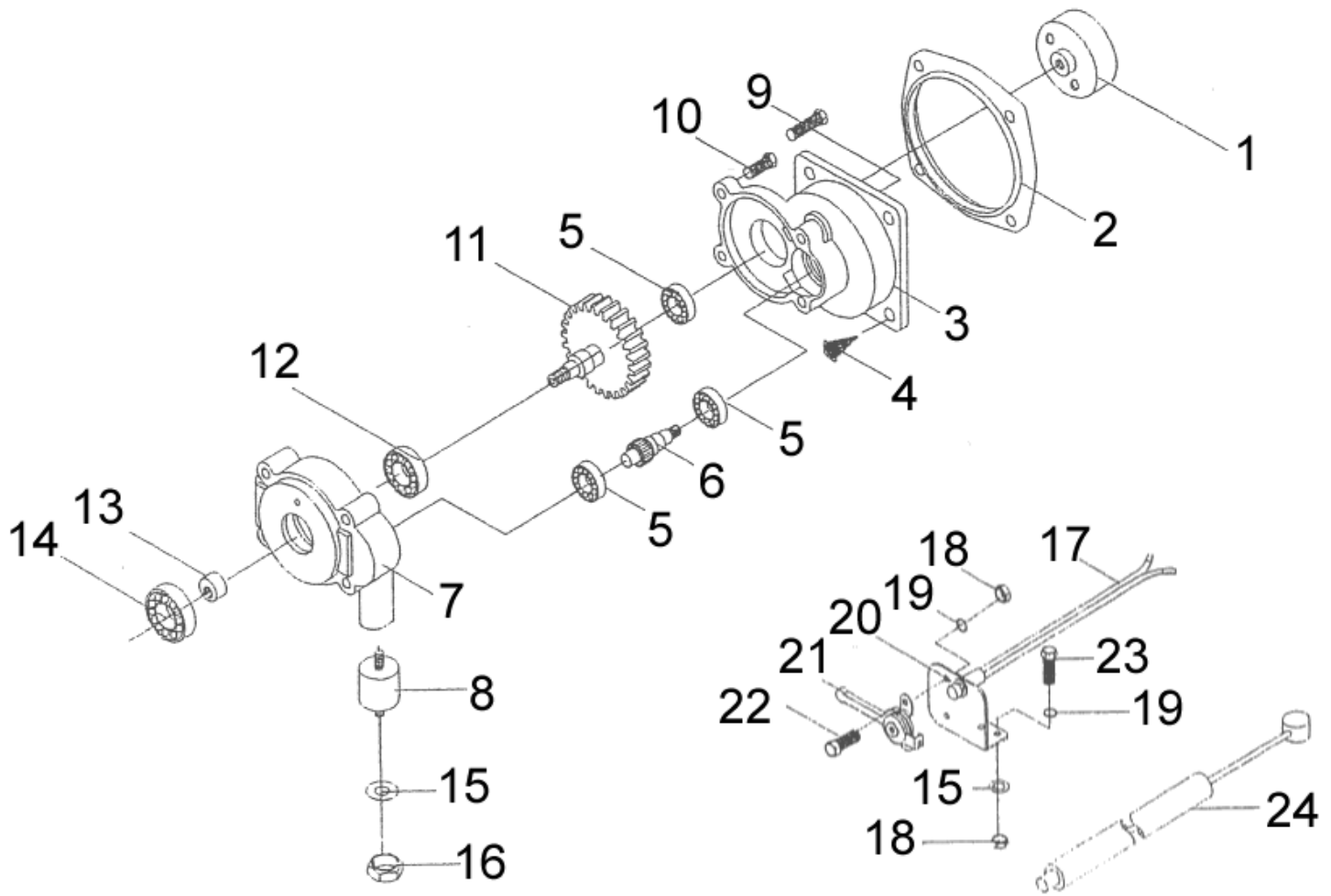

9433700_06

Bild-Nr. Pos.-No. Pos.-No.	Bestell-Nr. Order-No. No. de Cde Ref.-Nr.	Menge Quantity Nombres Cantidad	Adaption Kupplung-Pumpe, Gashebel	Combination clutch-pump, Throttle lever	Connexion embrayage-pompe, accélérateur	Conexión embrague- bomba, palanca gas
1	76 433 039	1	Kupplungsglocke	Clutch drum	Cloche embrayage	Campana de embrague
2	76 433 030	1	Flansch	Flange	Bride	Brida
3	76 916 026	1	Getriebe	Gear box	Engrenage	Engranaje
4	76 959 230	4	Schraube	Screw	Vis	Tornillo
5	76 959 035	3	Kugellager	Bearing(6000)	Roulement a billes	Cojinete de bolas
6	76 959 031	1	Getriebewelle	Shaft of smaller gear	Arbre de transmission	Arbol
7	76 959 027	1	Deckel, Getriebe	Gear box cover	Couvercle	Tapa
8	06 926 018	1	Stopfen	Shake-proof Plug (27L)	Bouchon	Tapon
9	76 959 205	2	Schraube	Screw M6 x 22L	Vis	Tornillo
10	76 959 204	2	Schraube	Screw M6 x 16L	Vis	Tornillo
11	76 959 028	1	Getriebewelle	Shaft of bigger gear	Arbre de transmission	Arbol
12	76 959 034	1	Kugellager	Bearing(6001)	Roulement a billes	Cojinete de bolas
13	76 959 037	1	Welle	Shaft, eccentric	Arbre	Arbol
14	76 959 033	1	Kugellager	Bearing(6004)	Roulement a billes	Cojinete de bolas
15	76 959 217	3	Scheibe	Washer M6 x 16	Rondelle	Arandela
16	76 959 215	1	Mutter	Anti-loose nut m6	Ecrou	Tuerca
17	76 926 016	1	Schalter Stop	Stop switch	Interrupteur	Interruptor
18	76 959 214	4	Mutter	Nut	Ecrou	Tuerca
19	76 959 216	4	Federscheibe	Spring washer	Rondelle	Arandela
20	76 926 014	1	Hebelaufnahme	Lever seat	Siege de levier	Asiento
21	06 926 014	1	Hebel	Lever	Levier	Palanca
22	76 959 210	2	Schraube	Screw	Vis	Tornillo
23	76 959 211	2	Schraube	Screw M6 x 16L	Vis	Tornillo
24	28 00 578	1	Gaszug	Throttle cable	Cable Bowden	Cable Bowden



Bild-Nr. Pos.-No. Pos.-No. Pos.-No.	Bestell-Nr. Order-No. No. de Cde Ref.-Nr.	Menge Quantity Nombres Cantidad	Pumpe	Pump	Pompe	Bomba
1	76 959 214	1	Mutter	Nut	Ecrou	Tuerca
2	76 959 216	1	Federscheibe	Spring washer	Rondelle	Arandela
3	76 959 217	1	Scheibe	Washer M6 x 16 mm	Rondelle	Arandela
4	76 959 066	1	Justierdeckel	Adjusting pan	Couvercle	Tapa
5	76 959 067	1	Mutter, ÜW	Fly nut	Ecrou	Tuerca
6	76 959 057	1	Flanschgehäuse	Overflow body	Carter	Carter
7	76 959 203	4	Schraube	Screw M5 x 50 mm	Vis	Tornillo
8	76 926 024	4	Schlauchschelle	5/8 Clamp hose	Collier	Abrazadera
9	76 959 025	1	Feder	Spring overflow	Ressort	Resorte
10	76 959 024	1	Schlauch	Overflow hose	Tube	Tubo
11	76 959 065	1	Verstellschraube	Regulating screw	Vis réglable	Tornillo
12	76 959 064	1	O-Ring	O-ring 9 x 2 mm	Joint torique	Anillo
13	76 959 062	1	Feder	Spring	Ressort	Resorte
14	76 959 061	1	Scheibe	Under metal	Rondelle	Arandela
15	76 959 060	1	Kugel	Stainless ball	Boule	Bola
16	76 959 058	1	O-Ring	O-ring 13 x 2,5	Joint torique	Anillo
17	76 959 059	1	Sitz	Seat, overflow valve	Siege	Asiento
18	76 959 077	1	O-Ring	O-ring 10 x 3 mm	Joint torique	Anillo
19	76 959 201	12	Schraube M5 x 28L	Screw M5 x 28 mm	Vis	Tornillo
20	76 959 049	1	Abdeckung	Overflow metal	Couvercle	Tapa
21	76 959 094	2	O-Ring	O-ring 30 x 2,5 mm	Joint torique	Anillo
22	76 959 044	2	Ventilfeder	Spring valve	Ressort	Resorte
23	76 959 042	2	Stopfen	Stopper	Bouchon	Tapon
24	76 959 040	4	O-Ring	O-ring 22 x 2 mm	Joint torique	Anillo
25	76 959 041	2	Ventilsitz	Valve seat	Siege de soupape	Asiento de valvula
26	76 959 088	2	Dichtung	Water seal box (hole)	Joint	Junta
27	76 959 045	2	Buchse	Tube, screw bush	Douille	Casquillo
28	76 959 087	2	Dichtung	Water seal box	Joint	Junta
29	76 959 051	2	Buchse, Zyl.	Cylinder bushing	Douille, Cyl.	Casquillo
30	76 959 093	2	Hochdrucksitz	High pressure water seal	Siege	Asiento
31	76 959 4560	2	Anschluss enth. (-> 31 - 33	Connecting pipe assy incl. (-> 31 - 33	Connection y inclus: (-> 31 - 33	Conexion incl. (-> 31 - 33
32	76 959 076	4	O-Ring	O-ring 8 x 2 mm	Joint torique	Anillo
33	76 959 056	2	Anschlussrohr<-)	Connecting pipe<-)	Tube de connection<-)	Tubo 66 <-)
35	76 959 4950	2	Sitz enth. (-> 35 - 38	Water seal seat assy incl. (-> 35 - 38	Siege y inclus: (-> 35 - 38	Asiento incl. (-> 35 - 38
36	76 959 096	2	O-Ring	O-ring 24,5 x 2 mm	Joint torique	Anillo
37	76 959 095	2	Sitz	Seat, water seal	Siege	Asiento
38	76 959 092	2	Dichtung<-)	Water seal <-)	Joint<-)	Junta <-)
39	76 959 048	2	Buchse	Plunger bushing	Douille	Casquillo
40	76 959 206	4	Schraube	Screw M6 x 50 mm	Vis	Tornillo
41	76 959 047	1	Abdeckung	Cover, anti-dust	Couvercle	Cubierta
42	76 959 046	1	Zylinder	Cylinder	Cylindre	Cilindro
43	76 959 052	1	Stößel	Plunger	Poussoir	Aguja
44	76 959 054	1	Stopfen	Plug	Bouchon	Tapon
45	76 959 053	1	Ansaugschlauch	Suction joint	Tube	Tubo
46	76 959 023	1	Feder	Suction spring	Ressort	Resorte
47	76 959 022	1	Ansaugschlauch	Suction hose	Tube	Tubo
48	76 959 050	1	Abdeckung	Discharge metal	Couvercle	Tapa
49	06 10 551	1	Pumpe komplett enth. (-> 1- 48 <-)	Pump cpl. incl. (-> 1- 48 <-)	Pompe y inclus: (-> 1- 48 <-)	Bomba incl. (-> 1- 48 <-)



9433700_08

Bild-Nr. Pos.-No. Pos.-No.	Bestell-Nr. Order-No. No. de Cde Ref.-Nr.	Menge Quantity Nombres Cantidad	Tragegestell, Behälter, Tragegurt	Carrying frame, tank, Carrying strap	Cadre porteur, réservoir, bretelle	Bastidor, deposito, cinturon portador
1	76 926 004	1	Scheibe	Washer	Rondelle	Arandela
2	76 926 003	1	Schutzkappe	Cowl	Capuchon	Caperuza
3	76 926 002	1	Tankdeckel	Tank hood	Couvercle réservoir	Tapa de deposito
4	76 926 005	1	Dichtung Tankdeckel	Seal, tank hood	Joint	Junta
5	76 926 006	1	Einfüllkorb	Sieve filling	Etonnoir	Cesta de relleno
6	76 968 001	1	Behälter	Water tank	Réservoir	Deposito
7	76 926 009	2	Tragegurt	Back belt	Bretelle	Cinturon portador
8	76 926 008	1	Dichtung	Gasket,plug drain	Joint	Junta
9	76 926 007	1	Verschlussstopfen	Drain cup	Bouchon	Tapon
10	76 959 217	14	Scheibe	Washer M6 x 16	Rondelle	Arandela
11	76 959 211	6	Schraube	Screw M6 x 16L	Vis	Tornillo
12	76 968 012	2	Strebe	Bracket	Tirant	Tirante
13	76 926 018	2	Stopfen	Shake-proof plug (20L)	Bouchon	Tapon
14	76 968 011	1	Rückenplatte	Chair seat	Plaque	Chapa
15	76 959 215	2	Mutter	Anti-loose nut M6	Ecrou	Tuerca
16	76 959 219	6	Schraube	Screw	Vis	Tornillo
17	76 926 025	1	Rückenkissen	Pad cushion	Coussin dorsal	Almohadilla
18	76 959 224	4	Dichtung	Washer	Joint	Junta

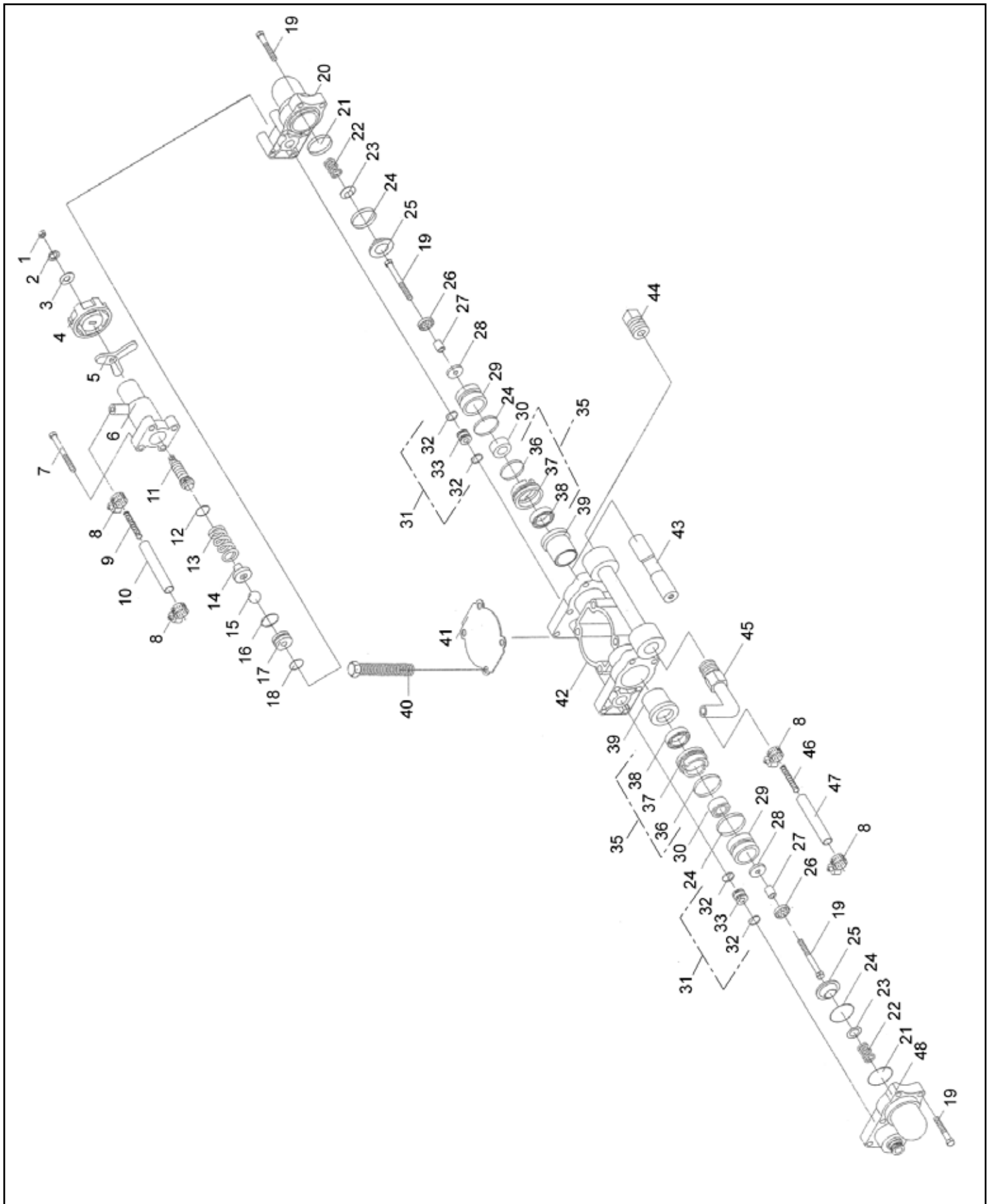
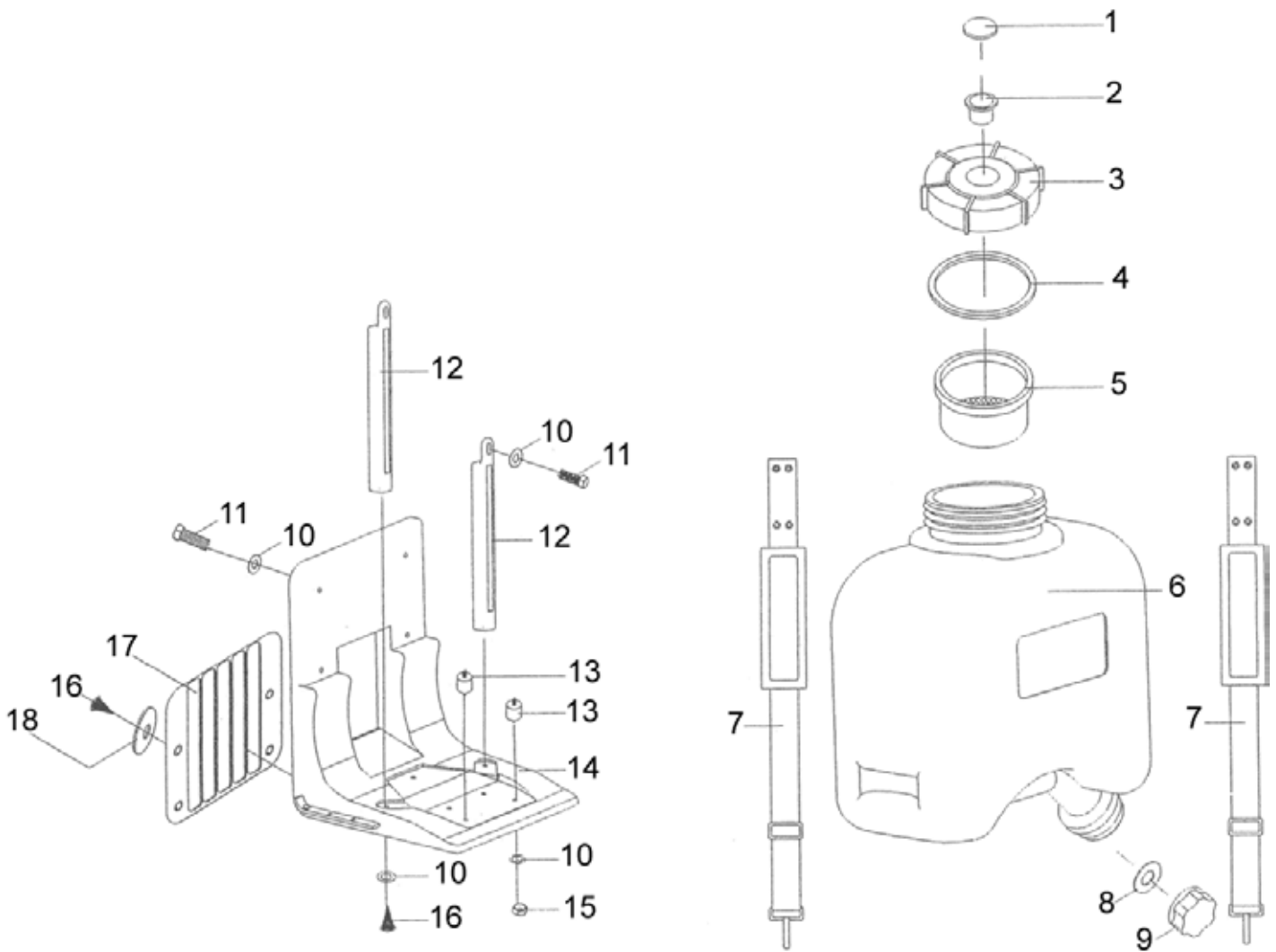
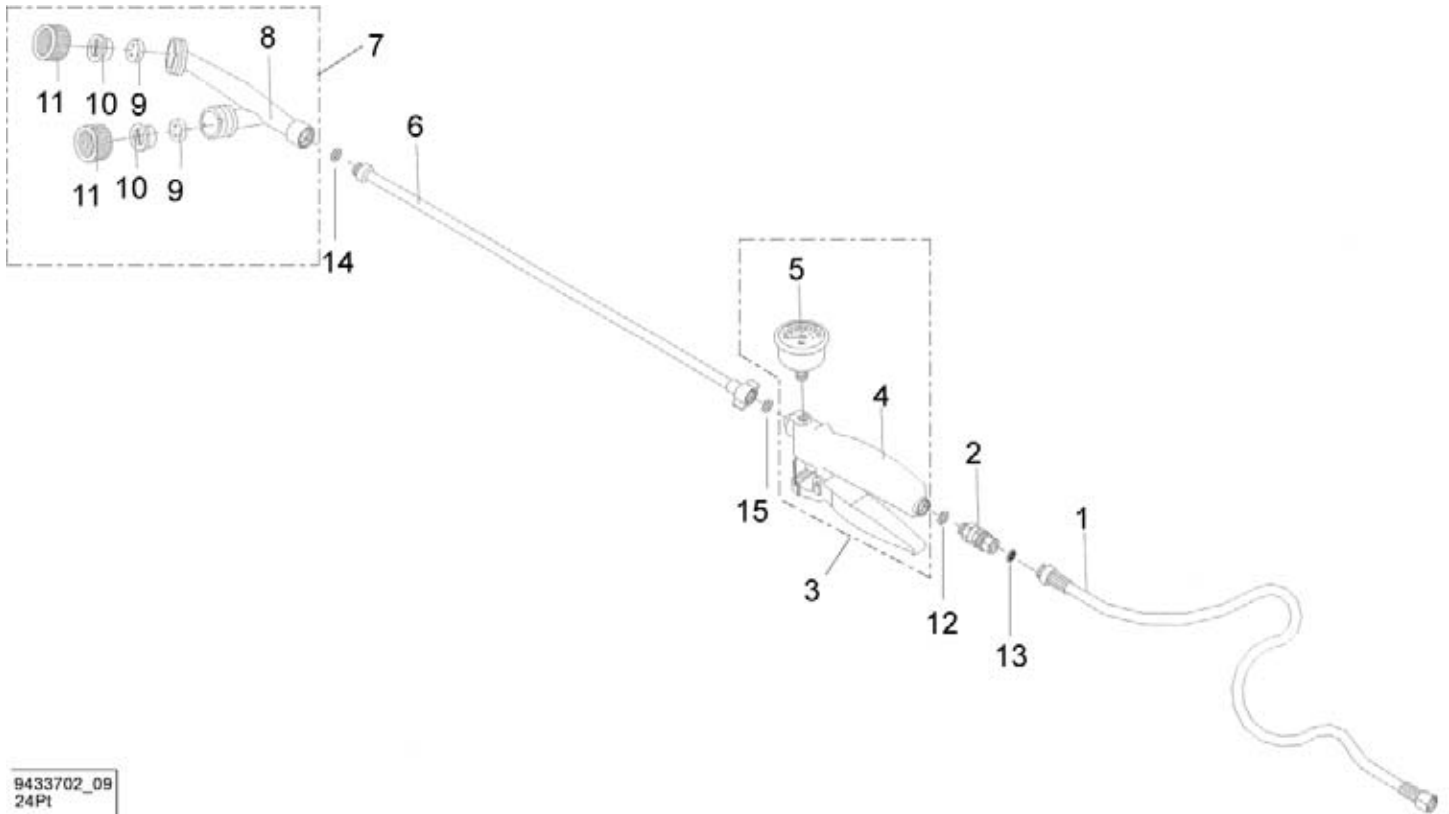

8433702_09
24PI

4900185 - LANCIA INOX 120cm CON UGELLO REGOLABILE



Bild-Nr. Pos.-No. Pos.-No.	Bestell-Nr. Order-No. No. de Cde Ref.-Nr.	Menge Quantity Nombres Cantidad	Spritzrohr	Spray wand	Tube de pulvérisation	Tubo
1	76 926 068	1	Hochdruckschlauch	High pressure spraying Hose	Tube haute pression	Tubo alto presion
2	76 926 085	1	Schlauchverbindung	Twirl Joint	Connection	Conexion
3	06 10 589	1	Griff inkl. Manometer	Handle grip, pressure gauge	Poignee, manometre	Empunadura, manometro
4	76 433 4069	1	Griff	Handle grip	Poignee	Empunadura
5	76 926 069	1	Manometer	Pressure Gauge	Manometre	Manometro
6	76 926 070	1	Spritzrohr	Spraying pipe	Tuyau pulverisateur	Tubo pulverizacion
7	76 926 089	1	Doppeldüse enth. (-> 7 - 11)	Y-shape Nozzle Assembly incl. (-> 7 - 11)	Buse double y inclus: (-> 7 - 11)	Tobera doble incl. (-> 7 - 11)
8	76 1200506	1	Doppeldüse	Y-shape Nozzle body	Buse double	Tobera doble
9	76 1200502	2	Düsenfilter	Nozzle filter with Gasket	Filtre de buse	Filtro de tobera
10	76 1200503	2	Düsenplatte	Nozzle plate	Plaque de buse	Placa de tobera
11	76 1200505	2	Mutter, ÜW<-)	Cover Nozzle plate <-)	Ecrou <-)	Tobera doble <-)
12	7692636901	1	O-Ring	O-ring	Joint torique	Anillo
13	76926086	1	Dichtung	Gasket,	Joint	Junta
14	769260701	1	Dichtung	Gasket,	Joint	Junta
15	769260700	1	Dichtung	Gasket,	Joint	Junta

Bestell-Nr. Order-No. No. de Cde Ref.-Nr.	Menge Quantity Nombres Cantidad	Seite Page Page Pagina	Bestell-Nr. Order-No. No. de Cde Ref.-Nr.	Menge Quantity Nombres Cantidad	Seite Page Page Pagina	Bestell-Nr. Order-No. No. de Cde Ref.-Nr.	Menge Quantity Nombres Cantidad	Seite Page Page Pagina	Bestell-Nr. Order-No. No. de Cde Ref.-Nr.	Menge Quantity Nombres Cantidad	Seite Page Page Pagina
00 10 519	1	6	05 10 985	1	3	40 73 442	1	3	76 959 049	1	8
00 10 564	2	3	06 10 551	1	8	60 63 341	1	5	76 959 050	1	8
00 15 300	2	4	06 10 589	1	11	76 1200502	2	11	76 959 051	2	8
00 18 257	1	2	06 926 014	1	7	76 1200503	2	11	76 959 052	1	8
00 18 274	2	2	06 926 018	1	7	76 1200505	2	11	76 959 053	1	8
00 18 275	4	5	20 00 643	1	2	76 1200506	1	11	76 959 054	1	8
00 18 326	1	2	20 11 819	1	3	76 433 030	1	7	76 959 056	2	8
00 18 337	2	3	20 31 902 25	1	2	76 433 039	1	7	76 959 057	1	8
00 18 354	4	6	20 31 965	1	6	76 433 4069	1	11	76 959 058	1	8
00 18 363	6	6	20 48 377	1	2	76 916 026	1	7	76 959 059	1	8
00 18 365	2	3	20 61 142	1	3	76 926 002	1	10	76 959 060	1	8
00 18 399	4	2	20 61 197	1	3	76 926 003	1	10	76 959 061	1	8
00 18 429	2	3	20 61 464	1	3	76 926 004	1	10	76 959 062	1	8
00 21 258	1	2	20 61 518	1	3	76 926 005	1	10	76 959 064	1	8
00 28 118	2	4	20 63 372	2	2	76 926 006	1	10	76 959 065	1	8
00 28 137	2	3	20 74 111	1	3	76 926 007	1	10	76 959 066	1	8
00 30 101	1	4	20 74 141	4	5	76 926 008	1	10	76 959 067	1	8
00 31 258	2	2	20 74 343	1	6	76 926 009	2	10	76 959 076	4	8
00 31 494	4	5	20 74 562	1	2	76 926 014	1	7	76 959 077	1	8
00 31 611	1	6	20 74 570	1	6	76 926 016	1	7	76 959 087	2	8
00 31 626	1	2	20 74 600	1	3	76 926 018	2	10	76 959 088	2	8
00 33 401	2	4	20 74 600	1	4	76 926 024	4	8	76 959 092	2	8
00 34 100	1	3	20 74 895	1	2	76 926 025	1	10	76 959 093	2	8
00 34 152	1	6	20 74 915	1	6	76 926 068	1	11	76 959 094	2	8
00 34 156	2	3	20 74 977	1	6	76 926 069	1	11	76 959 095	2	8
00 52 226	1	2	21 00 121 25	2	2	76 926 070	1	11	76 959 096	2	8
00 54 258	2	2	21 00 122	1	2	76 926 085	1	11	76 959 201	12	8
00 55 278	2	2	21 00 126	1	6	76 926 089	1	11	76 959 203	4	8
00 61 360	1	3	22 00 162	1	2	76 9260700	1	11	76 959 204	2	7
00 62 335	2	2	22 00 304 52	1	2	76 9260701	1	11	76 959 205	2	7
00 62 345	1	5	22 00160	1	2	76 926086	1	11	76 959 206	4	8
00 63 195 25	1	6	23 00 489	1	4	76 92636901	1	11	76 959 210	2	7
00 64 415 27	470 mm	4	23 00 726 10	1	3	76 959 022	1	8	76 959 211	2	7
00 64 420	1	5	23 00 730	1	4	76 959 023	1	8	76 959 211	6	10
00 64 420	1	5	24 00 311	1	2	76 959 024	1	8	76 959 214	4	7
00 66 455	1	4	25 00 104	1	3	76 959 025	1	8	76 959 214	1	8
00 69 890	1	6	25 00 654	1	3	76 959 027	1	7	76 959 215	1	7
00 72 140	4	2	25 00 811	1	3	76 959 028	1	7	76 959 215	2	10
00 72 140	1	3	25 00 816	1	3	76 959 031	1	7	76 959 216	4	7
00 72 140	2	3	26 00 140	1	6	76 959 033	1	7	76 959 216	1	8
00 72 144	2	3	26 00 284	1	6	76 959 034	1	7	76 959 217	3	7
00 72 144	4	5	27 00 135	1	5	76 959 035	3	7	76 959 217	1	8
00 72 148	2	4	27 00 187	1	5	76 959 037	1	7	76 959 217	14	10
00 72 176	1	2	27 00 264	1	5	76 959 040	4	8	76 959 219	6	10
00 73 360	1	4	27 00 430	1	5	76 959 041	2	8	76 959 224	4	10
00 73 365	1	6	28 00 578	1	7	76 959 042	2	8	76 959 230	4	7
00 75 100	1	2	28 00 593	1	4	76 959 044	2	8	76 959 4560	2	8
00 84 621	1	4	35 00 4651	1	2	76 959 045	2	8	76 959 4950	2	8
00 84 889	1	4	40 73 127	1	2	76 959 046	1	8	76 968 001	1	10
00 94 197	4	5	40 73 128	1	6	76 959 047	1	8	76 968 011	1	10
05 10 984	1	3	40 73 131	1	6	76 959 048	2	8	76 968 012	2	10

D
Allgemeine Richtlinien für die Bestellung von Original SOLO Ersatzteilen:
 Voraussetzung für eine reibungslose Erledigung sind folgende Angaben:
 1. Ersatzteil-Bestellnummer
 2. Gewünschte Anzahl
 3. Typenbezeichnung des Geräts
 Diese Ersatzteilliste ist für die Lieferung und Ausstattung von SOLO Erzeugnissen unverbindlich. Im Interesse der technischen Weiterentwicklung bleiben Konstruktionsänderungen vorbehalten.

GB
General Directions for Ordering Original SOLO Spare Parts:
 For correct and diligent processing of your order, please give the following information:
 1. Spare Part number
 2. Quantity
 3. Model and serial number
 4. Shipping instructions
 Delivery is made in accordance with our general sales and delivery conditions. This spare parts list is non-committal for us with regard to delivery and layout of SOLO products. In favour of technical improvements, design modifications are subject to change without notice.

F
Directives générales pour les commandes de pièces de rechange d'origine SOLO:
 Il est indispensable de préciser dans toutes les commandes de pièces:
 1. le numéro de référence de la pièce
 2. la quantité
 3. le type de la machine
 4. le mode d'expédition
 Les livraisons sont effectuées dans le cadre de nos conditions générales de vente. Toutes modifications réservées.

E
Directivas Generales de pedido de la firma SOLO:
 Por adelantado de un arreglo sin dificultades necesitamos siguientes indicaciones:
 1. Número de repuesto
 2. Numero de cantidad
 3. Modelo y número de serial
 4. Instrucción de Envío
 Esta lista de repuestos no es obligatoria para los envíos y/o forma de equipo de los productos SOLO. En el interés del constante desarrollo debemos reservarnos el derecho de cambios.