

solo[®]

Ersatzteilliste

Spare parts list

Liste de pièces de rechange

Lista de piezas de recambio

Blasgerät

Blower Unit

Balai Souffleur

Soplador de aire

471 KAT

472

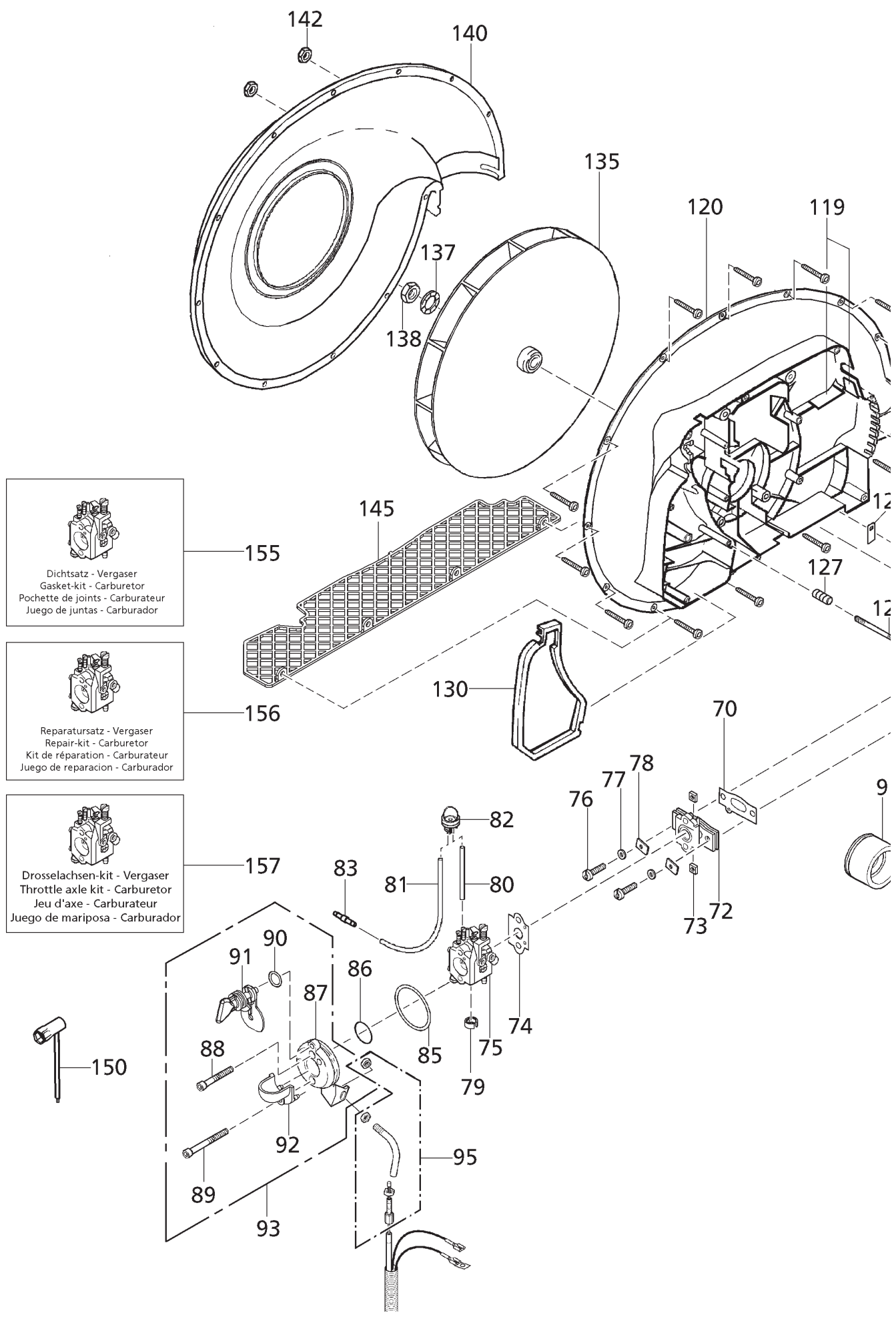

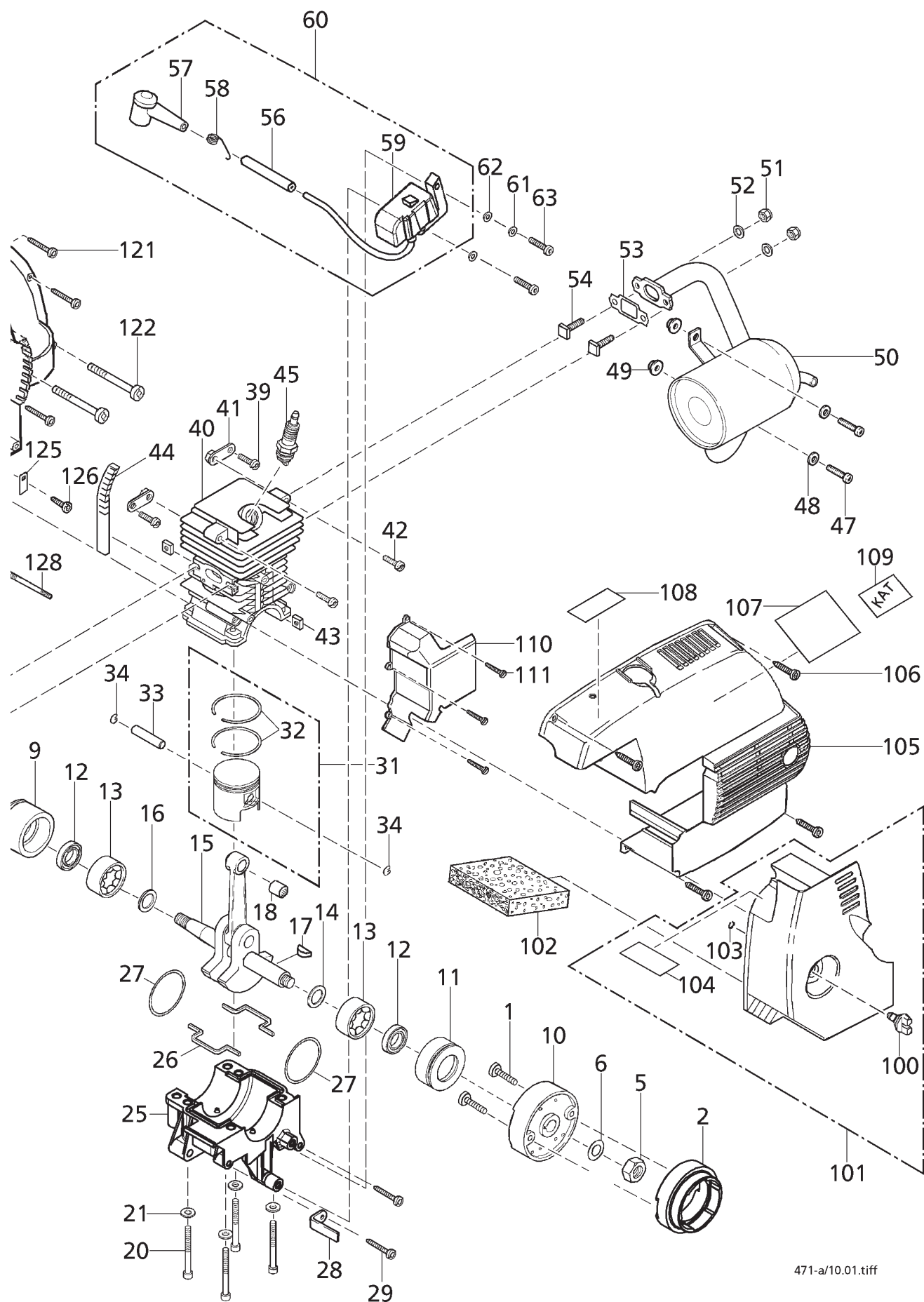

471-a/10.01.tiff

Bild-Nr. Pos.-No. Pos.-No. Pos.-No.	Bestell-Nr. Order-No. No. de Cde. Ref.-Nr.	Modell Type Modèle Modelo	Menge Quantity Nombres Cantidad	Motor/ Gebläse	Engine/ Blower Housing	Moteur/ Carter de Turbine	Motor/ Caja del Ventilador
1	00 18 363		2	Linsenschraube 5x20	screw	vis	tornillo
2	20 74 774		1	Anwurfrolle	ropepulley	poulie de lanceur	roldana de arranque
5	00 20 104		1	Sechskantmutter M10x1 DIN 934	nut	écrou	tuerca
6	00 34 135		1	Sicherungsscheibe 10	circlip	arrêtage	seguro
9	20 74 128		1	Lagerhülse 34,9x45,17x23,5	sleeve	douille	casquillo
10	23 00 774		1	Polrad	flywheel	volant magnétique	volante
11	20 74 294		1	Lagerhülse 34,9x45,17x17,2	sleeve	douille	casquillo
12	00 54 220		2	Wellendichtring 15x28x5	oil seal	joint spy	reten
13	00 50 102		2	Kugellager 15x35x11 DIN 6202 C	ball bearing	roulement à billes	cojinete de bolas
14	00 31 375		1	Scheibe 15,3x22x0,5	washer	rondelle	arandela
15	22 00 109		1	Kurbelwelle	crankshaft	vilebrequin	cigüenal
16	00 31 620		1	Scheibe 15,3x22x3,5	washer	rondelle	arandela
17	00 75 101		1	Scheibenfeder 3x3,7 DIN 6888	spring washer	rondelle ressort	resorte de disco
18	00 52 226		1	Nadelkäfig 9x13x12,5	needle bearing	roulement à aiguilles	casquillo de cojinete
20	00 18 340		4	Zylinderschraube M5x40	screw	vis	tornillo
21	00 72 140		4	Scheibe 5,2x12x0,5 DIN 2093	washer	rondelle	muelle de disco
25	21 00 653		1	Kurbelgehäuse, kompl.	crankcase, compl.	carter-moteur	carter de cigüenal
26	20 63 371		2	Dichtungsteil Kurbelgehäuse	crankcase gasket	joint carter moteur	empaquetadura
27	00 62 290		2	O-Ring 39x3	o-ring	joint torique	anillo
28	40 43 999		1	Halteblech	fixing plate	tôle de fixation	chapa fijacion
29	00 18 372		2	Linsenschraube 6x35	screw	vis	tornillo
31	22 00 248		1	Kolben Ø 42,00 mm	piston	piston	piston
32	20 48 229		2	Kolbenring 42x1,5	piston ring	segment	anillo de piston
33	20 31 117 25		1	Kolbenbolzen 9/6x28	piston pin	axe de piston	bulon de piston
34	00 55 278		2	Sicherungsring 9x0,8	piston pin circlip	circlip axe piston	anillo
39	00 18 369		2	Linsenschraube 6x16	screw	vis	tornillo
40	20 11 112	471 KAT	1	Nikasilzylinder Ø 42,00 mm	cylinder	cyindre	cilindro
40	20 11 111	472	1	Nikasilzylinder Ø 42,00 mm	cylinder	cyindre	cilindro
41	25 00 732		2	Lasche 19,9x2,5	flap	collier	eclisa
42	00 18 348		2	Zylinderschraube M6x25	screw	vis	tornillo
43	00 21 256		2	Vierkantmutter M5	nut	écrou	tuerca
44	40 63 160		1	Profilstück	profile	pièce profilée	perfil
45	23 00 730		1	Zündkerze WSR6F 200	spark plug	bougie	bujia
47	00 18 363		2	Linsenschraube 5x20	screw	vis	tornillo
48	00 72 144		2	Sicherungsscheibe 5 DIN 6796 A	tension washer	rondelle de tension	arandela elastica
49	20 74 562		2	Isolierement	insulator	élément d'isolation	elemento aislador
50	25 00 730	471 KAT	1	Auspuff	muffler	échappement	escape
50	25 00 749	472	1	Auspuff	muffler	échappement	escape
51	00 28 100		2	Sechskantmutter M6	nut	écrou	tuerca
52	00 72 143		2	Sicherungsscheibe 6 DIN 6796 A	tension washer	rondelle de tension	arandela
53	20 61 103		1	Auspuffdichtung	exhaust gasket	joint échappement	junta del escape
54	00 18 421		2	Vierkantschraube M6x20	screw	vis	tornillo
56	00 64 292		200 mm	Schlauch 6x1xmt.	hose	tuyau	tubo
57	00 84 600		1	Kerzenstecker	spark plug cap	capuchon de bougie	terminal de bujia
58	00 73 385		1	Kontaktfeder	contact spring	ressort de contact	resorte de contacto
59	23 00 203		1	Zündmodul	ignition coil	bobine d'allumage	bobina
60	23 00 204		1	Zündmodul, kompl., enth.(ignition coil, compl., incl.(bobine d'allumage,compl.incl.(bobina, compl.,incl.(
(56)	00 64 292		200 mm	Schlauch 6x1xmt.	hose	tuyau	tubo
(57)	00 84 600		1	Kerzenstecker	spark plug cap	capuchon de bougie	terminal de bujia
(58)	00 73 385		1	Kontaktfeder	contact spring	ressort de contact	resorte de contacto
(59)	23 00 203		1	Zündmodul)	ignition coil)	bobine d'allumage)	bobina)
61	00 30 135		1	Scheibe 4,3 DIN 125 A	washer	rondelle	arandela
62	00 72 148		2	Sicherungsscheibe 4 DIN 6796 A	washer	rondelle de tension	disco de tension
63	00 18 326		2	Zylinderschraube M4x16	screw	vis	tornillo
70	20 61 511		1	Vergaserstutzendichtung	manifold gasket	joint de bride	junta de brida
72	20 74 916	471 KAT	1	Vergaserstutzen Ø i. 8 mm	manifold	bride de carburateur	brida de carburador
72	20 74 540	472	1	Vergaserstutzen Ø i. 12 mm	manifold	bride de carburateur	brida de carburador
73	00 21 235		2	Vierkantmutter M5	nut	écrou	tuerca
74	20 61 515		1	Vergaserdichtung 0,7 mm	carburetor gasket	joint de carburateur	junta carburador
75	23 00 813	471 KAT	1	Vergaser 47B-102C	carburetor	carburateur	carburador
75	23 00 818	472	1	Vergaser 47B-101 C	carburetor	carburateur	carburador
76	00 18 338		2	Zylinderschraube 5x25	screw	vis	tornillo
77	00 72 144		2	Sicherungsscheibe 5 DIN 6796 A	tension washer	rondelle de tension	arandela elastica
78	40 42 817		2	Lasche	flap	collier	cubrejunta
79	20 74 905		1	Haltering	retaining ring	bague de support	anillo soporte
80	00 64 407		70 mm	Schlauch 2x1,5xmt.	hose	durite	tubo
81	00 64 300		285 mm	Schlauch 3x1,5xmt., Benzinrücklauf	hose	durite	tubo
82	27 00 322		1	Primer	primer	primer	primer
83	00 66 452		1	Stutzen	socket	manchon	munon
85	00 62 321		1	O-Ring 42x2,5 DIN 872	o-ring	joint torique	anillo
86	00 62 325		1	O-Ring 21x1,0	o-ring	joint torique	anillo
93	49 00 536		1	Bausatz Lufteintritt enth.:(modification kit	kit de modification	juego modificacion
(87)	20 74 962		1	Ansaugflansch	suction flange	bride	brida
(88)	00 10 107		2	Zylinderschraube M5x50 DIN 912	screw	vis	tornillo
(89)	00 10 595		1	Zylinderschraube M5x60 DIN 912	screw	vis	tornillo
(90)	00 62 263		1	O-Ring 12x2,5	o-ring	joint torique	anillo
(91)	20 74 961		1	Chokeklappe	choke flap	étrangleur	valvula
(92)	20 74 960		1	Flansch Lufteintritt)	flange)	bride d'admission)	brida)
95	28 00 566		1	Bowdenzug Gas	bowden cable gas	câble bowden gaz	cable bowden gas
100	68 00 286		1	Filtermutter M5x12,5	screw	écrou filtre	tornillo
101	41 00 109		1	Deckel Ansauggeräuschdämpf.enth.:(exhaust cover, incl.:(couvercle échappement, incl.:(cubierta, incl.:(
(100)	68 00 286		1	Filtermutter M5x12,5	screw	écrou filtre	tornillo

Bild-Nr. Pos.-No. Pos.-No. Pos.-No.	Bestell-Nr. Order-No. No. de Cde. Ref.-Nr.	Modell Type Modèle Modelo	Menge Quantity Nombres Cantidad	Motor/ Gebläse	Engine/ Blower Housing	Moteur/ Carter de Turbine	Motor/ Caja del Ventilador
(103)	00 55 279		1	Sicherungsring 8x0,8 DIN 7993	safety ring	bague de sécurité	anillo de seguridad
(104)	00 69 721		1	SKS "Choke"	sticker	autocollant	adhesivo
102	40 48 380		1	Filterplatte	filter plate	plaque de filtre	placa de filtro
103	00 55 279		1	Sicherungsring 8x0,8 DIN 7993	safety ring	bague de sécurité	anillo de seguridad
104	00 69 721		1	SKS "Choke"	sticker	autocollant	adhesivo
105	00 69 206		1	Motorabdeckung	engine cover	couvercle moteur	cubierta motor
106	00 18 363		4	Linsenschraube 5x20	screw	vis	tornillo
107	00 69 205	471 KAT	1	SKS "SOLO 471"	sticker "SOLO 471"	autocollant "SOLO 471"	adhesivo "SOLO 471"
107	00 69 206	472	1	SKS "SOLO 472"	sticker "SOLO 472"	autocollant "SOLO 472"	adhesivo "SOLO 472"
108	00 69 716		1	SKS "H-L-T"	sticker	autocollant	adhesivo
109	00 69 208	471 KAT	1	SKS "KAT"	sticker "KAT"	autocollant "KAT"	adhesivo "KAT"
110	20 73 503		1	Luftführung	air guide	guide d'air	guia de aire
111	00 18 363		3	Linsenschraube 5x20	screw	vis	tornillo
119	00 60 162	471 KAT	2	Isolierplatte	insulating plate	plaque d'isolation	chapa
120	40 73 700		1	Gebläsegehäuse 1	blower housing	carter de turbine	carter de turbina
121	00 18 363		12	Linsenschraube 5x20	screw	vis	tornillo
122	00 18 342		2	Zylinderschraube M5x60	screw	vis	tornillo
125	20 42 667		1	Klemmplatte	clamping plate	plaque de serrage	placa
126	00 18 362		1	Linsenschraube 5x10	screw	vis	tornillo
127	00 65 100		1	Gewindeinsatz	thread insert	insert fileté	inserción roscada
128	00 15 155		1	Stiftschraube	screw	vis	tornillo
130	40 61 908		1	Luftfilterdichtung	air filter gasket	joint filtre	junta de filtro
135	44 00 241		1	Laufrad	fan wheel	turbine	turbina
137	00 34 135		1	Sicherungsscheibe 10	circlip	arrêtage	seguro
138	00 20 104		1	Sechskantmutter M10x1 DIN 934	nut	écrou	tuerca
140	40 73 677		1	Gebläsegehäuse 2	blower housing	carter de turbine	carter de turbina
142	00 20 101		2	Sechskantmutter M5 DIN 934	nut	écrou	tuerca
145	40 73 154		1	Schutzgitter	protection screen	grille de protection	rejilla
150	00 80 509		1	Kombischlüssel SW19/T25	combi wrench	clef combi	llave combi
155	05 10 992		1	Dichtsatz-Vergaser 47 B	gasket-kit-carburetor	pochette de joints-carbureteur	juego de juntas-carburador
156	05 10 993		1	Reparaturatz-Vergaser 47 B	repair-kit-carburetor	kit de réparation-carbureteur	juego de reparacion-carburador
157	05 10 994		1	Drosselachsen-kit-Verg.47 B	throttle axle kit - carburetor	jeu d'axe - carbureteur	juego de mariposa - carburador



Bild-Nr. Pos.-No. Pos.-No.	Bestell-Nr. Order-No. No. de Cde. Ref.-Nr.	Modell Type Modèle Modelo	Menge Quantity Nombres Cantidad	Starter	Starter	Lanceur	Arranque
1	00 18 258		2	Linsenschraube 5x18	screw	vis	tornillo
2	00 18 338		2	Zylinderschraube M5x25	screw	vis	tornillo
3	00 72 144		2	Sicherungsscheibe 5 DIN 6796 A	tension washer	rondelle de tension	arandela elastica
5	21 00 120		1	Startergehäuse	starter housing	carter de lanceur	carter de arranque
8	00 63 195 25		1	Starterseil 3x1050	starter rope	corde de lanceur	cuerda de arranque
9	20 74 570		1	Startergriff	starter grip	poignée lanceur	empunadura arranque
12	26 00 284		1	Federkassette	spring cassette	cassette de ressort	caja de resorte
13	20 74 915		1	Seilrolle	rope pulley	poulie de lanceur	roldana
15	20 74 343		1	Starterklinke	starter pawl	cliquet de lanceur	trinquete
16	00 31 611		1	Scheibe 4,3x16x1	washer	rondelle	arandela
17	20 74 977		1	Kulisse, rot	template, red	coulisse, rouge	colisa, rojo
18	20 31 965		1	Distanzstück 4,3x12,5x5	spacer	butée d'espacement	espaciador
19	00 73 365		1	Federstecker 1,4	pin	goupille beta	clavija
21	00 18 384		1	Zylinderschraube 4x16	screw	vis	tornillo
22	00 34 152		1	Sicherungsscheibe 4S	circlip	rondelle	arandela
25	26 00 106		1	Starter, kompl.	starter, compl.	lanceur, compl.	arranque, compl.



Bild-Nr. Pos.-No. Pos.-No.	Bestell-Nr. Order-No. No. de Cde. Ref.-Nr.	Modell Type Modèle Modelo	Menge Quantity Nombres Cantidad	Tragegestell	Frame	Châssis	Bastidor
2	40 73 682		1	Bodenplatte	bottom plate	plaque basse	chapa
3	00 18 274		2	Linsenschraube 5x16	screw	vis	tornillo
4	00 30 102		2	Scheibe 5,3 DIN 9021 A	washer	rondelle	arandela
5	00 18 275		2	Linsenschraube 5x30	screw	vis	tornillo
6	00 61 361		1	Filz	felt	feutre	fieltro
7	27 00 351		1	Benzintank, enth.: (fuel tank	réservoir d'essence	deposito gasolina
(8)	27 00 416		1	Filter - Benzinsucher	fuel pick-up	filtre, crepine essence	filtro gasolina
(9)	00 73 352		1	Schlauchöse	grommet	oeillet	ojete
(10)	60 63 328		1	Kraftstoffschlauch	fuel hose	tuyau d'essence	tubo de gasolina
(11)	00 73 351		1	Schlauchöse	grommet	oeillet	manguito de cable
(12)	80 63 247		2	Tülle	socket	douille	embocadura
(13)	27 00 395		1	Tankverschluß, kompl.	tank cap, compl.	bouchon réservoir, compl.	cierra de deposito, compl.
(14)	00 61 280		1	Deckeldichtung 35x45,3x2)	lid gasket)	joint de couvercle)	junta)
15	00 66 452		2	Stutzen	socket	manchon	munon
16	00 64 300		70 mm	Schlauch 3x1,5	hose	tuyau	tubo
17	00 64 300		240 mm	Schlauch 3x1,5	hose	tuyau	tubo
18	27 00 405		1	Entlüftungsstutzen	ventil socket	raccord aeration	munon
25	40 35 904		1	Rohrbügel 22x1,5	handle loop	arceau	tubo portante
30	40 42 577		2	Spannplatte	tension plate	plaque de tension	placa de tension
31	00 73 396		4	Dämpfungsfeder 3x19x26	AV spring	ressort amortisseur	resorte de antivibración
32	60 43 107		4	Flanschblech	flange plate	tôle bride	chapa
33	00 18 363		8	Linsenschraube 5x20	screw	vis	tornillo
35	40 46 100		2	Spannbügel	tension bracket	étrier de tension	aro de tension
40	00 18 363		2	Linsenschraube 5x20	screw	vis	tornillo
41	40 74 126		2	Kappe	cap	capuchon	caperuza
42	40 74 275		2	Gurtbefestigung	strap holder	porte-bretelle	soporte de cinturon
45	40 73 680		1	Rückenplatte	back plate	plaque dorsale	placa de espalda
46	00 44 144		5	Steckniet 5,7x18	cushion rivet	rivet	remache
48	00 98 101		1	Rückenkissen	back cushion	coussin dorsale	almohadilla
50	00 18 370		3	Linsenschraube 6x20	screw	vis	tornillo
51	00 18 369		1	Linsenschraube 6x16	screw	vis	tornillo
60	43 00 332		2	Tragegurt, enth.: (shoulder strap, incl.: (bretelle, incl.: (cinturon portador, incl.: (
(55)	40 74 921 25		2	Gurtschließe	strap clamp	fermeture bretelle	cierra de cinturon
(56)	43 00 335 25		2	Tragegurt)	shoulder strap)	bretelle)	cinturon portador)
57	40 74 412		2	Gurthalter, schwarz	strap holder, black	porte-bretelle	hebillas

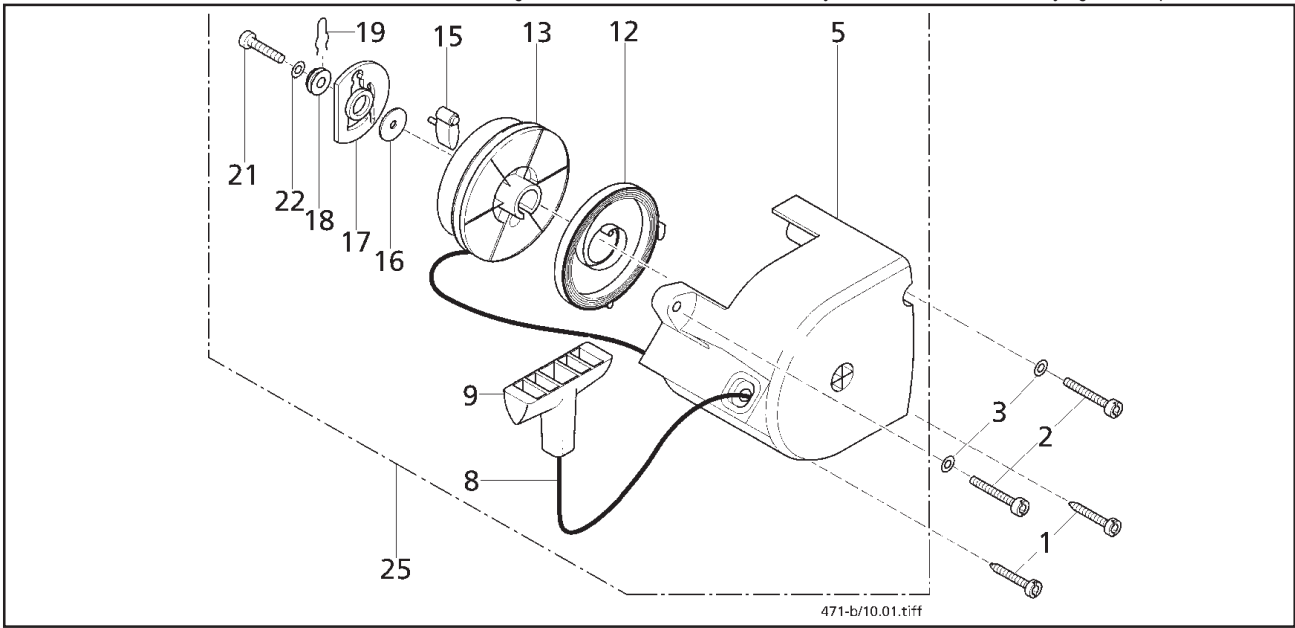

Bild-Nr. Pos.-No. Pos.-No. Pos.-No.	Bestell-Nr. Order-No. No. de Cde. Ref.-Nr.	Modell Type Modèle Modelo	Menge Quantity Nombres Cantidad	Blasrohr	Air tube	Tube de soufflerie	Tubo soplador
1	40 71 289		1	Krümmter 64x336	elbow	coude	codo
2	40 71 288		1	Blasrohr 61/64x425	tube	tube	tubo
4	44 00 248		1	Blasrohr 62,5/68,5x430	tube	tube	tubo
5	00 66 399		1	Schelle 68x10, kompl., enth.:(clamp, compl.(collier, compl.(abrazadera, compl.(
(6)	00 21 257		1	Vierkantmutter M5	square nut	écrou	tuerca
(7)	00 11 274		1	Zylinderschraube M5x50)	f.h.screw)	vis t.c.)	tornillo)
8	40 71 148		1	Faltenschlauch 92D	pleated hose	tuyau pliable	tubo plegable
10	00 66 130		1	Klemmschelle 83	clamp	collier	abrazadera
11	00 18 275		1	Linsenschraube 5x30	screw	vis	tornillo
15	44 00 109		1	Gebälsekrümmer VS, enth.:(elbow (coude (codo (
(16)	00 18 361		4	Linsenschraube 5x12	screw	vis	tornillo
(17)	40 73 466		1	Abdeckung)	cover)	couvercle)	cubierta)
22	48 00 222		1	Griffhälfte links, kompl.	grip half left, compl.	poignée moitié gauche, compl.	empuñadura izquierda
25	00 73 408		1	Drehfeder 1x9	spring	ressort	resorte
26	40 73 673		1	Gashebel	throttle lever	levier à gaz	palanca de gas
27	00 55 101		1	Sicherungsscheibe 4 DIN 6799	tension washer	rondelle	arandela
30	40 74 938		1	Griffhälfte, außen	outer grip half	poignée ext., moitié	maneta
33	00 18 356		4	Linsenschraube 4x20	screw	vis	tornillo
34	00 18 357		3	Linsenschraube 4x25	screw	vis	tornillo
35	00 64 415 27		1	Wellschlauch 8,5	tube	tuyau	tubo
36	00 84 477		1	Kurzschlußschalter	short circuit switch	interrupteur	interruptor
37	28 00 566		1	Bowdenzug Gas	bowden cable gas	câble de bowden gaz	cable de bowden gas
39	00 84 855		1	Massekabel, Kurzschlußkabel	short-circuit cable	câble court-circuit	cable cortocircuito

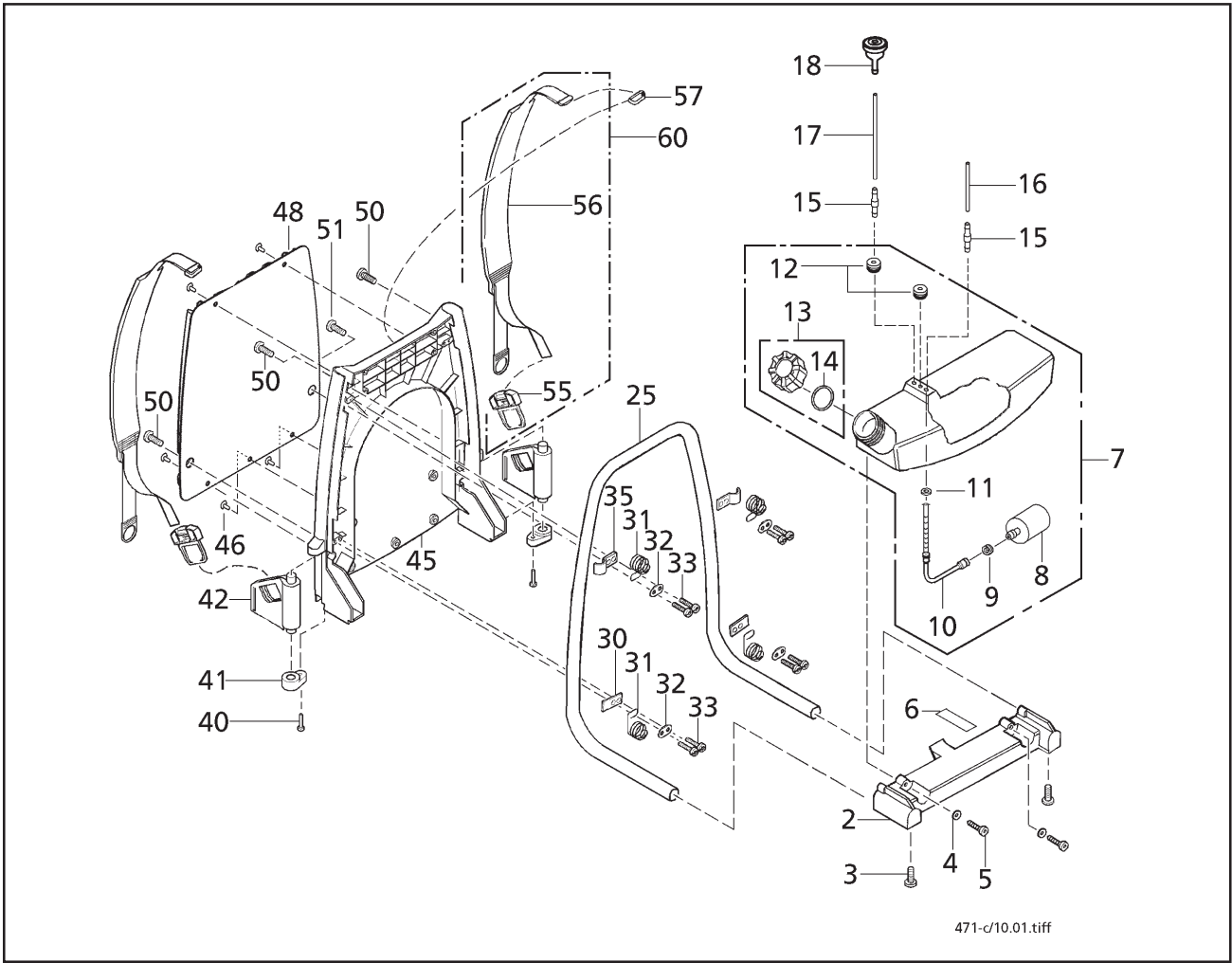

Bild-Nr. Pos.-No. No.Pos. Pos.-No.	Bestell-Nr. Order-No. No. de Cde Ref.-Nr.	Menge Quantity Nombres Cantidad	Neuer Luftfilter, modifiziertes Lüfterrad (472) ab 2005	New parts 2005 Improved air filter, fan wheel (472)	Nouveaux pièces 2005 Filtre à air, turbine (472)	Nuevo partes 2005 Filtro de aire, turbina (472)
1	40 74 901	1	Ansaugflansch	Inlet flange	Bride	Brida de aspiración
2	00 62 321	1	O-Ring 42 x 2,5 mm	O-ring	Joint torique	Anillo
3	00 62 325	1	O-Ring 21 x 1 mm	O-ring	Joint torique	Anillo
4	00 10 107	2	Zylinderschraube M5 x 50 mm	Screw	Vis	Tornillo
5	40 74 902	1	Choke-Klappenhebel	Choke lever	Levier starter	Juego palanca
6	00 62 263	1	O-Ring 12 x 2,5 mm	O-ring	Joint torique	Anillo
7	40 74 903	1	Luftführung (Vergaserseite)	Air guide (carbureto side)	Guide d'air (part carburateur)	Soporte de aire
8	00 18 361	3	Linsenschraube 5 x 12 mm	Screw	Vis	Tornillo
9	60 63 322	1	Verbindungsschlauch	Connecting hose	Tuyau connexion	Tubo flexible
10	40 74 904	1	Luftführung (Filterseite)	Air guide (filter side)	Guide d'air (part filtre)	Guia de Aire
11	20 48 280	1	Luftfilter	Air filter	Filtre à air	Filtro de aire
12	41 00 109	1	Luftfilterdeckel	Air filter cover	Chapeau filtre	Tapa de filtro
13	20 61 515	1	Vergaserdichtung	Carbureto gasket	Joint de carburateur	Junta carburador
14	50 74 159	1	Kappe	Plug	Capuchon	Casquete
15	44 00 241	1	Lüfterrad (450, 471)	Fan wheel (450, 471)	Turbine (450, 471)	Turbina (450, 471)
15	44 00 277 52	1	Lüfterrad (472)	Fan wheel (472)	Turbine (472)	Turbina (472)

D
**Allgemeine Richtlinien
für die Bestellung von
Original SOLO Ersatzteilen:**

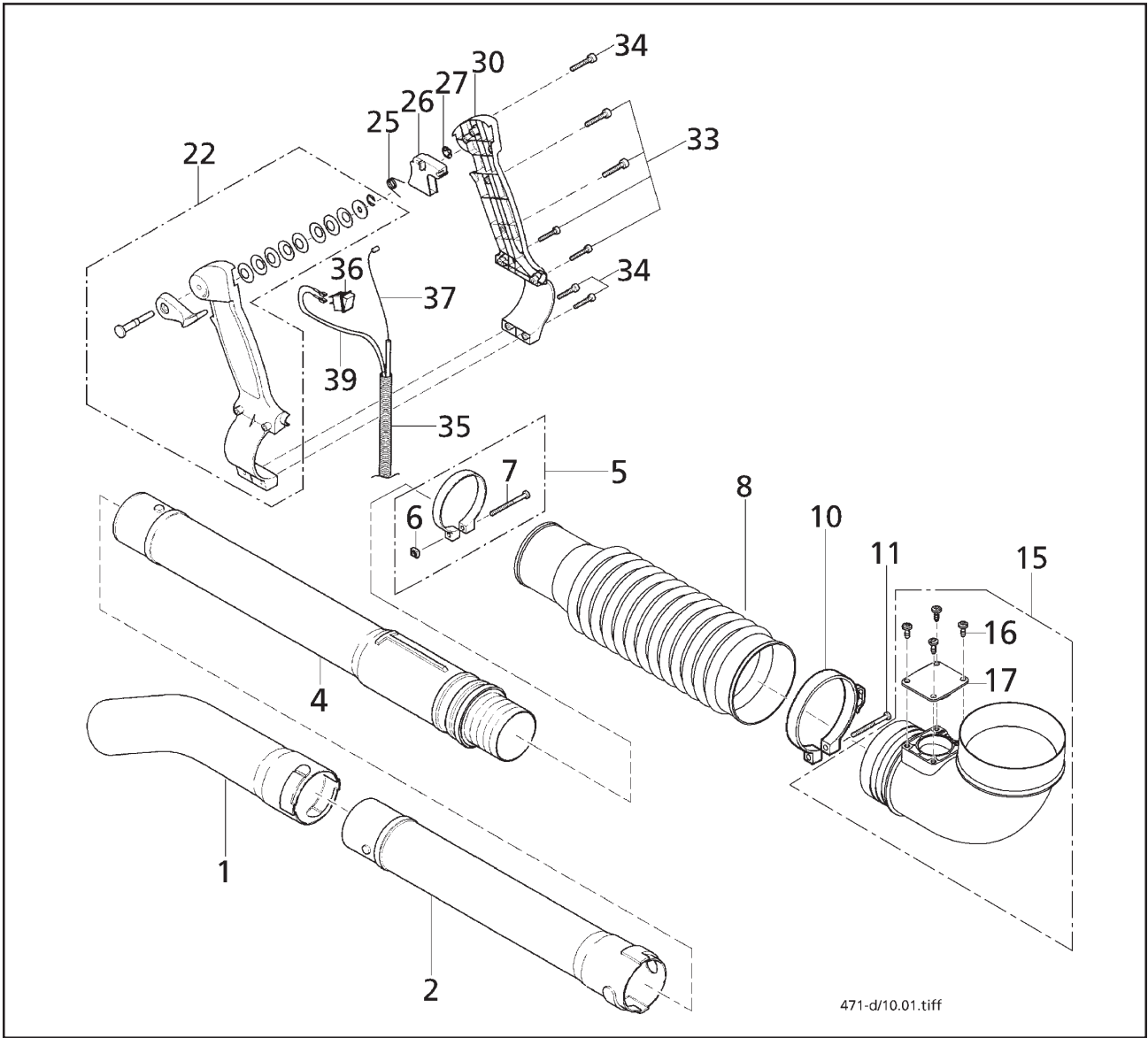
Voraussetzung für eine reibungslose Erledigung sind folgende Angaben:

1. Ersatzteil-Bestellnummer
2. Gewünschte Anzahl
3. Typenbezeichnung des Geräts

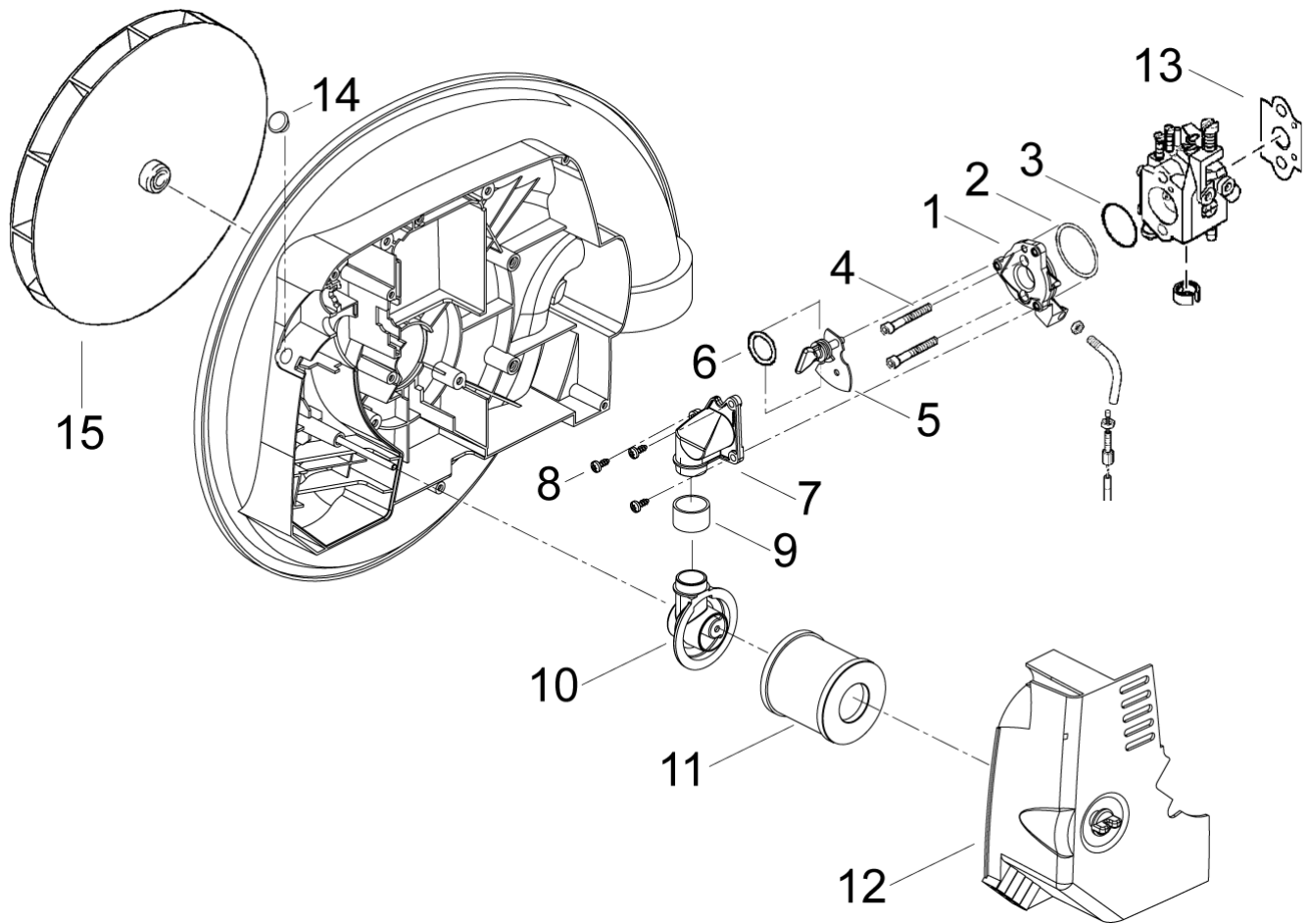
Diese Ersatzteilliste ist für die Lieferung und Ausstattung von SOLO Erzeugnissen unverbindlich. Im Interesse der technischen Weiterentwicklung bleiben Konstruktionsänderungen vorbehalten.

GB
**General Directions for
Ordering Original SOLO
Spare Parts:**

For correct and diligent processing of your order, please give the following information:

1. Spare Part number
2. Quantity
3. Model and serial number
4. Shipping instructions

Delivery is made in accordance with our general sales and delivery conditions. This spare parts list is non-committal for us with regard to delivery and layout of SOLO products. In favour of technical improvements, design modifications are subject to change without notice.

F
**Directives générales pour
les commandes de pièces
de rechange d'origine SOLO:**

Il est indispensable de préciser dans toutes les commandes de pièces:

1. le numéro de référence de la pièce
2. la quantité
3. le type de la machine
4. le mode d'expédition

Les livraisons sont effectuées dans le cadre de nos conditions générales de vente. Toutes modifications réservées.

E
**Directivas Generales de
pedido de la firma SOLO:**

Por adelantado de un arreglo sin dificultades necesitamos siguientes indicaciones:

1. Número de repuesto
2. Numero de cantidad
3. Modelo y número de serial
4. Instrucción de Envío

Esta lista de repuestos no es obligatoria para los envíos y/o forma de equipo de los productos SOLO. En el interés del constante desarrollo debemos reservarnos el derecho de cambios.

Bestell-Nr. Order-No. No. de Cde. Ref.-Nr.	Menge Quantity Nombres Cantidad	Seite page page pagina	Bestell-Nr. Order-No. No. de Cde. Ref.-Nr.	Menge Quantity Nombres Cantidad	Seite page page pagina	Bestell-Nr. Order-No. No. de Cde. Ref.-Nr.	Menge Quantity Nombres Cantidad	Seite page page pagina	Bestell-Nr. Order-No. No. de Cde. Ref.-Nr.	Menge Quantity Nombres Cantidad	Seite page page pagina
00 10 107	2	4	00 44 144	5	6	00 84 477	1	7	26 00 106	1	5
00 10 595	1	4	00 50 102	2	4	00 84 600	1	4	26 00 284	1	5
00 11 274	1	7	00 52 226	1	4	00 84 855	1	7	27 00 322	1	4
00 15 155	1	5	00 54 220	2	4	00 98 101	1	6	27 00 351	1	6
00 18 258	2	5	00 55 101	1	7	05 10 992	1	5	27 00 395	1	6
00 18 274	2	6	00 55 278	2	4	05 10 993	1	5	27 00 405	1	6
00 18 275	2	6	00 55 279	1	4	05 10 994	1	5	27 00 416	1	6
00 18 275	1	7	00 60 162	2	5	20 11 111	1	4	28 00 566	1	4
00 18 326	2	4	00 61 280	1	6	20 11 112	1	4	28 00 566	1	7
00 18 338	2	4	00 61 361	1	6	20 31 117 25	1	4	40 35 904	1	6
00 18 338	2	5	00 62 263	1	4	20 31 965	1	5	40 42 577	2	6
00 18 340	4	4	00 62 290	2	4	20 42 667	1	5	40 42 817	2	4
00 18 342	2	5	00 62 321	1	4	20 48 229	2	4	40 43 999	1	4
00 18 348	2	4	00 62 325	1	4	20 61 103	1	4	40 46 100	2	6
00 18 356	4	7	00 63 195 25	1	5	20 61 511	1	4	40 48 380	1	4
00 18 357	3	7	00 64 292	200 mm	4	20 61 515	1	4	40 61 908	1	5
00 18 361	4	7	00 64 300	320 mm	4	20 63 371	2	4	40 63 160	1	4
00 18 362	1	5	00 64 300	70 mm	6	20 73 503	1	5	40 71 148	1	7
00 18 363	2	4	00 64 300	240 mm	6	20 74 128	1	4	40 71 288	1	7
00 18 363	2	4	00 64 407	70 mm	4	20 74 294	1	4	40 71 289	1	7
00 18 363	4	5	00 64 415 27	1	7	20 74 343	1	5	40 73 154	1	5
00 18 363	3	5	00 65 100	1	5	20 74 540	1	4	40 73 466	1	7
00 18 363	12	5	00 66 130	1	7	20 74 562	2	4	40 73 673	1	7
00 18 363	8	6	00 66 399	1	7	20 74 570	1	5	40 73 677	1	5
00 18 363	2	6	00 66 452	1	4	20 74 774	1	4	40 73 679	1	4
00 18 369	2	4	00 66 452	2	6	20 74 905	1	4	40 73 680	1	6
00 18 369	1	6	00 69 205	1	5	20 74 915	1	5	40 73 682	1	6
00 18 370	3	6	00 69 206	1	5	20 74 916	1	4	40 73 700	1	5
00 18 372	2	4	00 69 208	1	5	20 74 960	1	4	40 74 126	2	6
00 18 384	1	5	00 69 716	1	5	20 74 961	1	4	40 74 275	2	6
00 18 421	2	4	00 69 721	1	4	20 74 962	1	4	40 74 412	2	6
00 20 101	2	5	00 72 140	4	4	20 74 977	1	5	40 74 921 25	2	6
00 20 104	1	4	00 72 143	2	4	21 00 120	1	5	40 74 938	1	7
00 20 104	1	5	00 72 144	2	4	21 00 653	1	4	41 00 109	1	4
00 21 235	2	4	00 72 144	2	4	22 00 109	1	4	43 00 332	2	6
00 21 256	2	4	00 72 144	2	5	22 00 248	1	4	43 00 335 25	2	6
00 21 257	1	7	00 72 148	2	4	23 00 203	1	4	44 00 109	1	7
00 28 100	2	4	00 73 351	1	6	23 00 204	1	4	44 00 241	1	5
00 30 102	2	6	00 73 352	1	6	23 00 730	1	4	44 00 248	1	7
00 30 135	1	4	00 73 365	1	5	23 00 774	1	4	48 00 222	1	7
00 31 611	1	5	00 73 385	1	4	23 00 813	1	4	49 00 536	1	4
00 31 620	2	4	00 73 396	4	6	23 00 818	1	4	60 43 107	4	6
00 34 135	1	4	00 73 408	1	7	25 00 730	1	4	60 63 328	1	6
00 34 135	1	5	00 75 101	1	4	25 00 732	2	4	68 00 286	1	4
00 34 152	1	5	00 80 509	1	5	25 00 749	1	4	80 63 247	2	6

Allgemeine Richtlinien für die Bestellung von Original SOLO Ersatzteilen:

Voraussetzung für eine reibungslose Erledigung sind folgende Angaben:

1. Ersatzteil-Bestellnummer
2. Gewünschte Anzahl
3. Typenbezeichnung des Geräts

Diese Ersatzteilliste ist für die Lieferung und Ausstattung von SOLO Erzeugnissen unverbindlich.

Im Interesse der technischen Weiterentwicklung bleiben Konstruktionsänderungen vorbehalten.

General Directions for Ordering Original SOLO Spare Parts:

Spare parts orders are to be placed with the SOLO Sales Branch or SOLO Distributor. For correct and diligent processing of your order, please give the following information:

1. Spare Part number
2. Quantity
3. Model and serial number
4. Shipping instructions

Delivery is made in accordance with our general sales and delivery conditions. This spare parts list is non-committal for us with regard to delivery and layout of SOLO products. In favour of technical improvements, design modifications are subject to change without notice.

Directives générales pour les commandes de pièces de rechange d'origine SOLO:

Il est indispensable de préciser dans toutes les commandes de pièces:

1. - le numéro de référence de la pièce
2. - la quantité
3. - le type de la machine
4. - le mode d'expédition

Les livraisons sont effectuées dans le cadre de nos conditions générales de vente. Toutes modifications réservées.

Directivas Generales de pedido de la firma SOLO:

Por adelantado de un arreglo sin dificultades necesitamos siguientes indicaciones:

1. Número de repuesto
2. Numero de cantidad
3. Modelo y número de serial
4. Instrucción de Envío

Este lista de repuestos no es obligatoria para los envíos y/o forma de equipo de los productos SOLO.

En el interés del constante desarrollo debemos reservarnos el derecho de cambios.

SOLO Kleinmotoren GmbH

Postfach 60 01 52
D-71050 Sindelfingen
Germany

Telefon 07031/301-0
Telefax 07031/301-130
Export 07031/301-149

<http://www.solo-germany.com>
e-mail: info@solo-germany.com

Zentral-Ersatzteilservice

Telefon 07031/301-209
Telefax 07031/301-206 12/2001

solo[®]