D	<i>Ersatzteilliste</i>	Rückenspritze	424 NOVA	Inhaltsverzeichnis	Seite
				Behälter, Tragegurt ,Pumpe	2
				Spritzrohr, Handventil, Düse	3
				Ersatzteile	4
				Bestell-Richtlinien	4
GB	<i>Spare parts list</i>	Backpack Sprayer	424 NOVA	Table of contents	Page
				Tank, Carrying strap, Pump	2
				Spray wand	3
				Spare Parts	4
				Directions for Ordering	4
F	<i>Liste de pièces de rechange</i>	Pulvérisateur à Dos	424 NOVA	Table des matières	Page
				Réservoir, Bretelle, Pompe	2
				Tuyau pulvérisation	3
				Pièces de rechange	4
				Directives pour les commandes	4
E	<i>Lista de piezas de recambio</i>	Pulverizador de Mochila	424 NOVA	Indice	Página
				Deposito, Cinturon portador, Bomba	2
				Tubo	3
				Piezas de recambio	4
				Directivas de pedido	4

<http://www.solo-germany.com>
e-mail: info@solo-germany.com

Telefon 07031/301-0
Telefax 07031/301-130
Export 07031/301-149

Zentral-Ersatzteilservice
Telefon 07031/301-209
Telefax 07031/301-206

SOLO Kleinmotoren GmbH
Postfach 60 01 52
D-71050 Sindelfingen
Germany

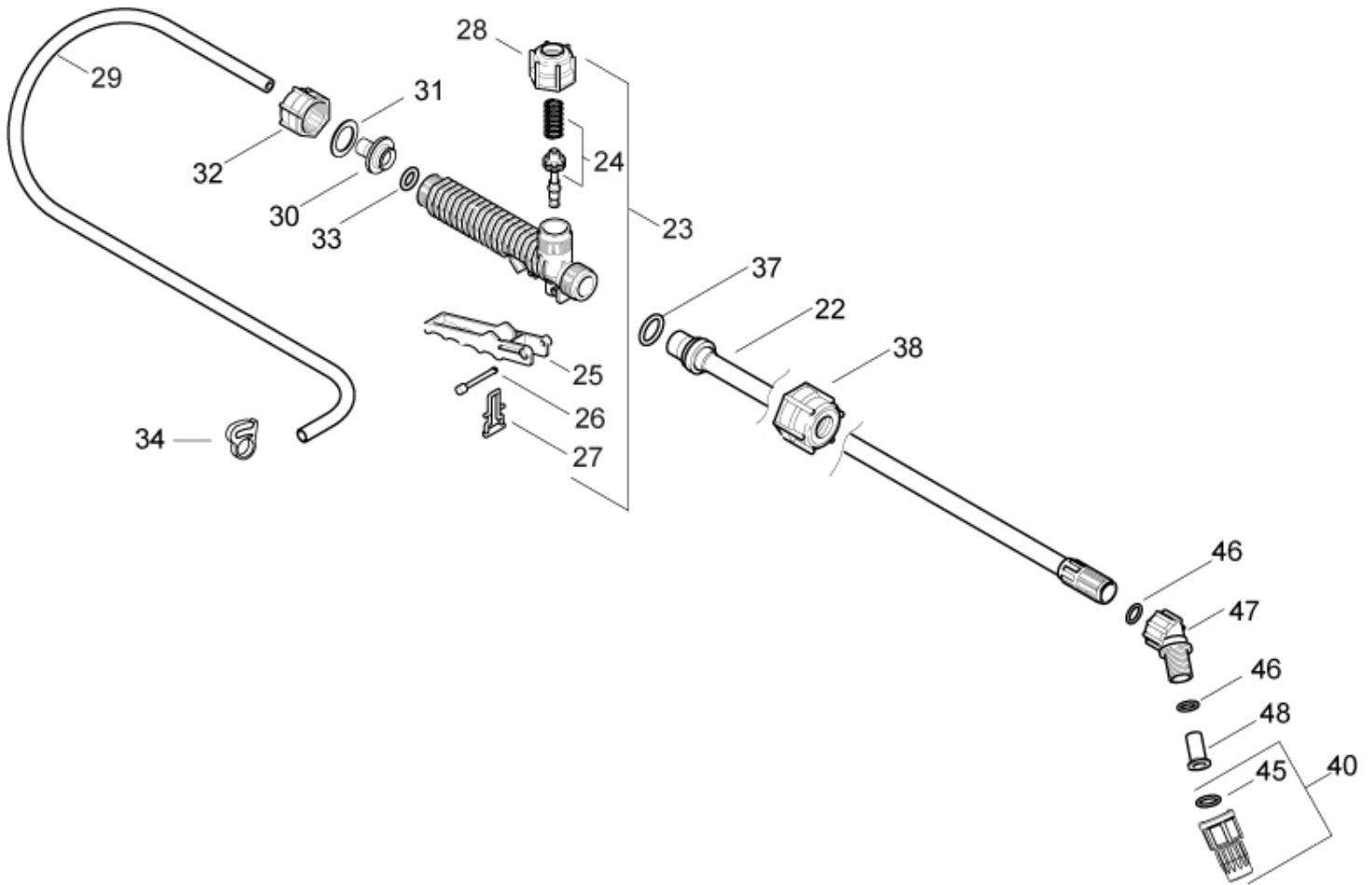

Bild-Nr. Pos.-No. Pos.-No. Pos.-No.	Bestell-Nr. Order-No. No. de Cde Ref.-Nr.	Menge Quantity Nombres Cantidad	Spritzrohr	Spray wand	Tube de pulvérisation	Tubo
22	13545	1	Spritzrohr	Spray tube	Tube de pulvérisation	Tubo
23	13457	1	Handventil enth. (-> 23 - 28)	Shut-off valve incl. (-> 23 - 28)	Robinet d'arrêt y inclus (-> 23 - 28)	Empunadura incl. (-> 23 - 28)
24	11631	1	Reparaturset Handventil	Repair kit	Jeu de réparation	Juego rep.
25	13095	1	Handhebel	Lever	Levier	Palanca
26	13073	1	Bolzen 4,8x26,5 mm	Bolt	Goujon	Perno
27	13085	1	Haltebügel	Support bracket	Crochet	Estribo
28	13098	1	Überwurfmutter R 3/4" (-)	Screw cap (-)	Écrou de raccord (-)	Tuerca (-)
29	14298	1	PVC-Schlauch 10x15x1300	Hose	Tuyau	Manguera
30	13154	1	Klemmstück	Clamp	Pièce de serrage	Abrazadera
31	10302	1	Scheibe 16,5x24x1 mm	Washer	Rondelle	Arandela
32	13100	1	Überwurfmutter R3/4"	Screw cap	Écrou de raccord	Tuerca
33	10679	1	O-Ring 10x3 mm	O-ring	Joint torique	Anillo
34	14300	1	Schelle	Clamp	Collier	Abrazadera
37	10672	1	O-Ring 16x3 mm	O-ring	Joint torique	Anillo
38	13100	1	Überwurfmutter R 3/4"	Screw cap	Écrou de raccord	Tuerca
40	13596	1	Hochstrahldüse enth. (-> 40,45)	Adjust. Nozzle, red incl. (-> 40,45)	Gicleur ajustable y inclus (-> 40,45)	Tobera chorro alto incl. (-> 40,45)
45	10626	1	O-Ring 12x2 mm (-)	O-ring (-)	Joint torique (-)	Anillo (-)
46	10630	2	O-Ring 10x2 mm	O-ring	Joint torique	Anillo
47	13174	1	Winkelstück R 3/8"	Elbow	Coude	Codo
48	13224	1	Filtereinsatz	Filter insert	Élément filtre	Filtro