

D	<i>Ersatzteilliste</i>	Motor-Druckspritze	433-03 Honda	Inhaltsverzeichnis	Seite
				Verbindung Kupplung-Pumpe, Gashebel	2
				Pumpe	3
				Tragegestell, Behälter, Tragegurt	5
				Spritzrohr	6
				Ersatzteile	7
				Bestell-Richtlinien	7
GB	<i>Spare parts list</i>	Motor-Sprayer	433-03 Honda	Table of contents	Page
				Combination clutch-pump, throttle lever	2
				Pump	3
				Carrying frame, tank, Carrying strap	5
				Spray wand	6
				Spare Parts	7
				Directions for Ordering	7
F	<i>Liste de pièces de rechange</i>	Pulvérisateur à moteur	433-03 Honda	Table des matières	Page
				Connexion embrayage-pompe, accélérateur	2
				Pompe	3
				Cadre porteur, réservoir, bretelle	5
				Tube de pulvérisation	6
				Pièces de rechange	7
				Directives pour les commandes	7
E	<i>Lista de piezas de recambio</i>	Pulverizador motorizado	433-03 Honda	Indice	Página
				Conexión embrague-bomba, palanca gas	2
				Bomba	3
				Bastidor, deposito, cinturon portador	5
				Tubo	6
				Piezas de recambio	7
				Directivas de pedido	7



Bild-Nr. Pos.-No. Pos.-No.	Bestell-Nr. Order-No. No. de Cde Ref.-Nr.	Menge Quantity Nombres Cantidad	Adaption Kupplung-Pumpe, Gashebel	Combination clutch-pump, Throttle lever	Connexion embrayage-pompe, accélérateur	Conexión embrague- bomba, palanca gas
1	76 926 039	1	Kupplungsglocke	Clutch drum	Cloche embrayage	Campana de embrague
3	76 926 026	1	Deckel, Getriebe	Gear box	Engrenage	Engranaje
4	00 10 123	4	Schraube	Screw	Vis	Tornillo
5	76 959 035	3	Kugellager	Bearing	Roulement a billes	Cojinete de bolas
6	76 959 031	1	Getriebewelle	Shaft of smaller gear	Arbre de transmission	Arbol
7	76 959 027	1	Deckel, Getriebe	Gear box cover	Couvercle	Tapa
8	06 926 018	1	Gummielment	Shake-proof Plug	Bouchon	Tapon
9	76 959 205	2	Schraube	Screw	Vis	Tornillo
10	76 959 204	2	Schraube	Screw	Vis	Tornillo
11	76 959 028	1	Getriebewelle	Shaft of bigger gear	Arbre de transmission	Arbol
12	76 959 034	1	Kugellager	Bearing	Roulement a billes	Cojinete de bolas
13	76 959 037	1	Welle	Shaft, eccentric	Arbre	Arbol
14	76 959 033	1	Kugellager	Bearing	Roulement a billes	Cojinete de bolas
15	76 959 2161	3	Scheibe	Washer	Rondelle	Arandela
17	76 926 016	1	Schalter Stop	Stop switch	Interrupteur	Interruptor
18	76 959 214	4	Mutter	Nut	Ecrou	Tuerca
19	76 959 216	12	Federscheibe	Spring washer	Rondelle	Arandela
20	76 926 014	1	Hebelaufnahme	Lever seat	Siege de levier	Asiento
21	06 926 014	1	Hebel	Lever	Levier	Palanca
22	76 959 210	2	Schraube	Screw	Vis	Tornillo
23	76 959 2121	2	Schraube	Screw	Vis	Tornillo
24	77 926 015	1	Gaszug	Throttle cable	Cable Bowden	Cable Bowden
25	76 926 021	1	Verstellmutter	Adjuster-Nut	Réglage- Ecrou	Regulación- Tuerca
26	76 959 2111	1	Schraube	Screw	Vis	Tornillo
27	00 11 105	1	Verstellschraube	Adjust screw	Vis	Tornillo
28	00 20 116	2	Mutter	Nut	Ecrou	Tuerca
29	00 66 455	1	Kabelband	Cable band	Frein de câble	Cinta



Bild-Nr. Pos.-No. Pos.-No.	Bestell-Nr. Order-No. No. de Cde Ref.-Nr.	Menge Quantity Nombres Cantidad	Pumpe	Pump	Pompe	Bomba
1	76 959 2151	1	Mutter	Nut	Ecrou	Tuerca
2	76 959 216	1	Federscheibe	Spring washer	Rondelle	Arandela
3	76 959 217	1	Scheibe	Washer M6 x 16 mm	Rondelle	Arandela
4	76 959 066	1	Justierdeckel	Adjusting pan	Couvercle	Tapa
5	76 959 067	1	Mutter, ÜW	Fly nut	Ecrou	Tuerca
6	76 959 057	1	Flanschgehäuse	Overflow body	Carter	Carter
7	76 959 203	4	Schraube	Screw M5 x 50 mm	Vis	Tornillo
8	76 926 024	2	Schlauchschelle	5/8 Clamp hose	Collier	Abrazadera
9	76 959 025	1	Feder	Spring overflow	Ressort	Resorte
10	76 959 024	1	Schlauch	Overflow hose	Tube	Tubo
11	76 959 065	1	Verstellerschraube	Regulating screw	Vis réglable	Tornillo
12	77 959 065	1	O-Ring	O-ring 9 x 2 mm	Joint torique	Anillo
13	76 959 062	1	Feder	Spring	Ressort	Resorte
14	76 959 061	1	Scheibe	Under metal	Rondelle	Arandela
15	76 959 060	1	Kugel	Stainless ball	Boule	Bola
16	76 959 058	1	O-Ring	O-ring 13 x 2,5	Joint torique	Anillo
17	76 959 059	1	Sitz	Seat, overflow valve	Siege	Asiento
18	76 959 077	1	O-Ring	O-ring 10 x 3 mm	Joint torique	Anillo
19	76 959 210	12	Schraube M5 x 28L	Screw M5 x 28 mm	Vis	Tornillo
20	76 959 049	1	Abdeckung	Overflow metal	Couvercle	Tapa
21	76 959 094	2	O-Ring	O-ring 30 x 2,5 mm	Joint torique	Anillo
22	76 959 044	2	Ventilfeder	Spring valve	Ressort	Resorte
23	76 959 042	2	Stopfen	Stopper	Bouchon	Tapon
24	76 959 040	4	O-Ring	O-ring 22 x 2 mm	Joint torique	Anillo
25	76 959 041	2	Ventilsitz	Valve seat	Siege de soupape	Asiento de valvula
26	76 959 088	2	Dichtung	Water seal box (hole)	Joint	Junta
27	76 959 045	2	Buchse	Tube, screw bush	Douille	Casquillo
28	76 959 087	2	Dichtung	Water seal box	Joint	Junta
29	76 959 051	2	Buchse, Zyl.	Cylinder bushing	Douille, Cyl.	Casquillo
30	76 959 093	2	Hochdrucksitz	High pressure water seal	Siege	Asiento
32	76 959 076	4	O-Ring	O-ring 8 x 2 mm	Joint torique	Anillo
33	76 959 056	2	Anschlussrohr	Connecting pipe	Tube de connection	Tubo 66
35	76 959 4950	2	Sitz enth. (-> 35 - 38	Water seal seat assy incl. (-> 35 - 38	Siege y inclus: (-> 35 - 38	Asiento incl. (-> 35 - 38
36	76 959 096	2	O-Ring	O-ring 24,5 x 2 mm	Joint torique	Anillo
37	76 959 095	2	Sitz	Seat, water seal	Siege	Asiento
38	76 959 092	2	Dichtung<-)	Water seal <-)	Joint<-)	Junta <-)
39	76 959 048	2	Buchse	Plunger bushing	Douille	Casquillo
40	76 959 206	4	Schraube	Screw M6 x 50 mm	Vis	Tornillo
41	76 959 047	1	Abdeckung	Cover, anti-dust	Couvercle	Cubierta
42	76 959 046	1	Zylinder	Cylinder	Cylindre	Cilindro
43	76 959 052	1	Stößel	Plunger	Poussoir	Aguja
44	76 959 054	1	Stopfen	Plug	Bouchon	Tapon
45	76 959 053	1	Ansaugschlauch	Suction joint	Tube	Tubo
46	76 433 023	1	Feder	Suction spring	Ressort	Resorte
47	76 959 022	1	Ansaugschlauch	Suction hose	Tube	Tubo
48	76 959 050	1	Abdeckung	Discharge metal	Couvercle	Tapa
50	76 27 076	2	O-Ring 16*2	O-ring	Joint torique	Anillo
51	76 926 024	2	Schlauchschelle	Clamp	Collier	Abrazadera

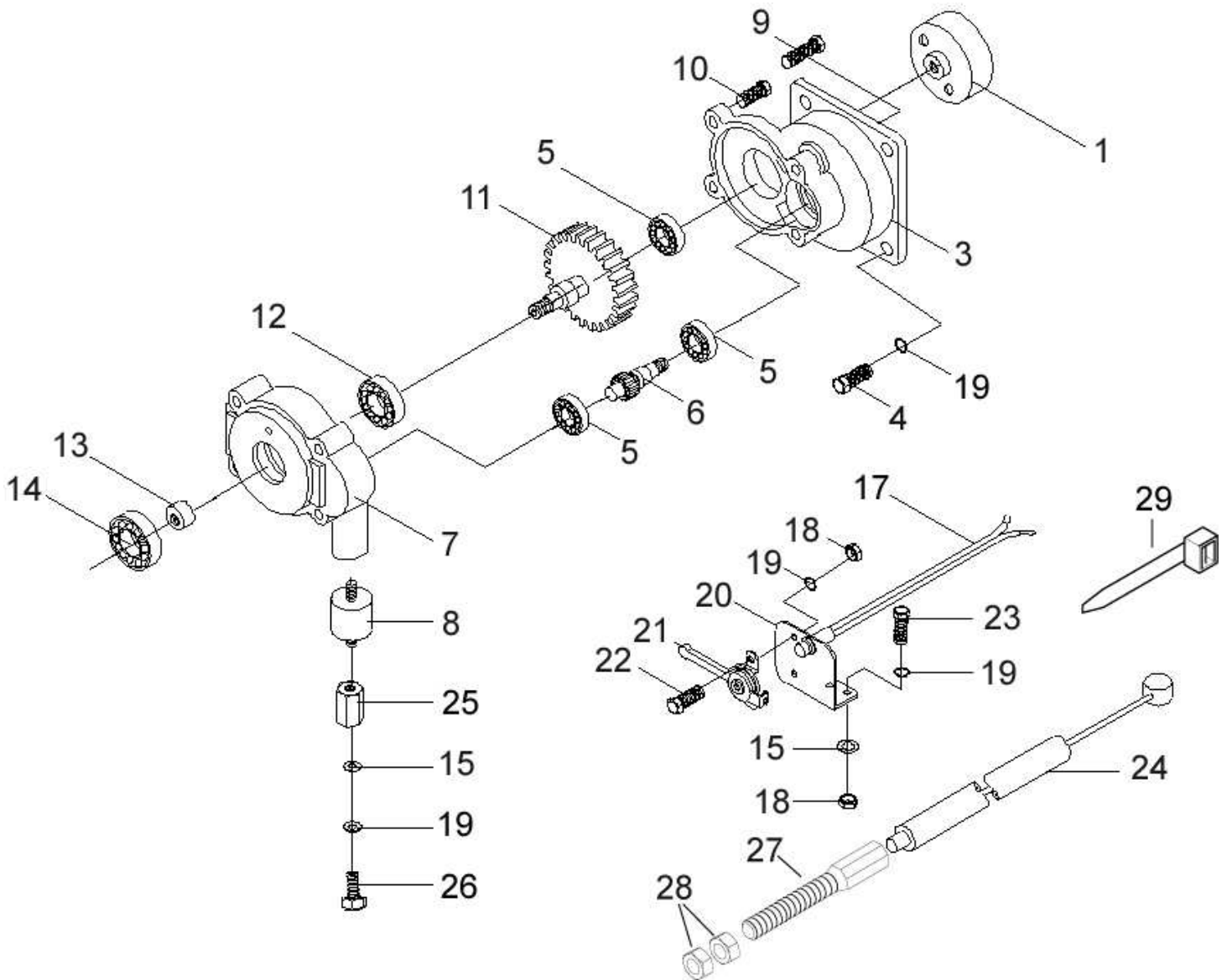

Bild-Nr. Pos.-No. Pos.-No. Pos.-No.	Bestell-Nr. Order-No. No. de Cde Ref.-Nr.	Menge Quantity Nombres Cantidad	Tragegestell, Behälter, Tragegurt	Carrying frame, tank, Carrying strap	Cadre porteur, réservoir, bretelle	Bastidor, deposito, cinturon portador
1	76 926 004	1	Scheibe	Washer	Rondelle	Arandela
2	76 926 003	1	Schutzkappe	Cowl	Capuchon	Caperuza
3	76 926 002	1	Tankdeckel	Tank hood	Couvercle réservoir	Tapa de deposito
4	76 926 005	1	Dichtung Tankdeckel	Seal, tank hood	Joint	Junta
5	76 926 006	1	Einfüllkorb	Sieve filling	Etonnoir	Cesta de relleno
6	76 968 001	1	Behälter	Water tank	Réservoir	Deposito
7	76 926 009	2	Tragegurt	Back belt	Bretelle	Cinturon portador
8	76 926 008	1	Dichtung	Gasket,plug drain	Joint	Junta
9	76 926 007	1	Verschlussstopfen	Drain cup	Bouchon	Tapon
10	76 959 217	8	Scheibe	Washer	Rondelle	Arandela
11	76 959 010	6	Schraube	Screw	Vis	Tornillo
12	76 968 013	2	Strebe	Bracket	Tirant	Tirante
13	76 926 018	3	Stopfen	Shake-proof plug	Bouchon	Tapon
14	76 968 019	1	Rückenplatte	Chair seat	Plaque	Chapa
15	76 959 215	3	Mutter	Anti-loose nut	Ecrou	Tuerca
16	76 959 219	8	Schraube	Screw	Vis	Tornillo
17	76 926 025	1	Rückenkissen	Pad cushion	Coussin dorsal	Almohadilla
18	76 959 224	4	Formscheibe	Washer	Joint	Junta
19	00 28 121	6	Flügel-Mutter	Hex. Nut	Ecrou crante	Tuerca
20	77 959 010	6	O-Ring	O-ring	Joint torique	Anillo
21	77 959 004	1	O-Ring	O-ring	Joint torique	Anillo
22	76 959 2141	6	Mutter	Nut	Ecrou	Tuerca
23	76 959 2161	12	Scheibe	Washer	Joint	Junta
24	76 968 019	1	Motor-Befestigung	Base plate	Plaque de base	Chapa
25	76 959 209	3	Scheibe	Washer	Joint	Junta
26	76 959 208	1	Schraube	Screw	Vis	Tornillo
27	77 926 016	1	Massekabel	Ground cable	Câble de masse	Cable de masa
28	76 968 002	1	Spritzrohrhalter	Tube support	Support de tube	Soporte
29	00 18 193	2	Schraube	Screw	Vis	Tornillo
30	00 68 619	1	SKS 5x Warnhinweis	Decal	Autocollant	Adhesivo
31	00 68 621	1	SKS Warnhinweis Atemschutz	Decal	Autocollant	Adhesivo
32	00 68 425	1	SKS Warnhinweis Feuergef. Stoffe	Decal	Autocollant	Adhesivo
33	00 68 429	1	SKS Warnhinweis Abstand	Decal	Autocollant	Adhesivo
34	00 68 239	1	SKS Inhaltstoffe	Decal	Autocollant	Adhesivo

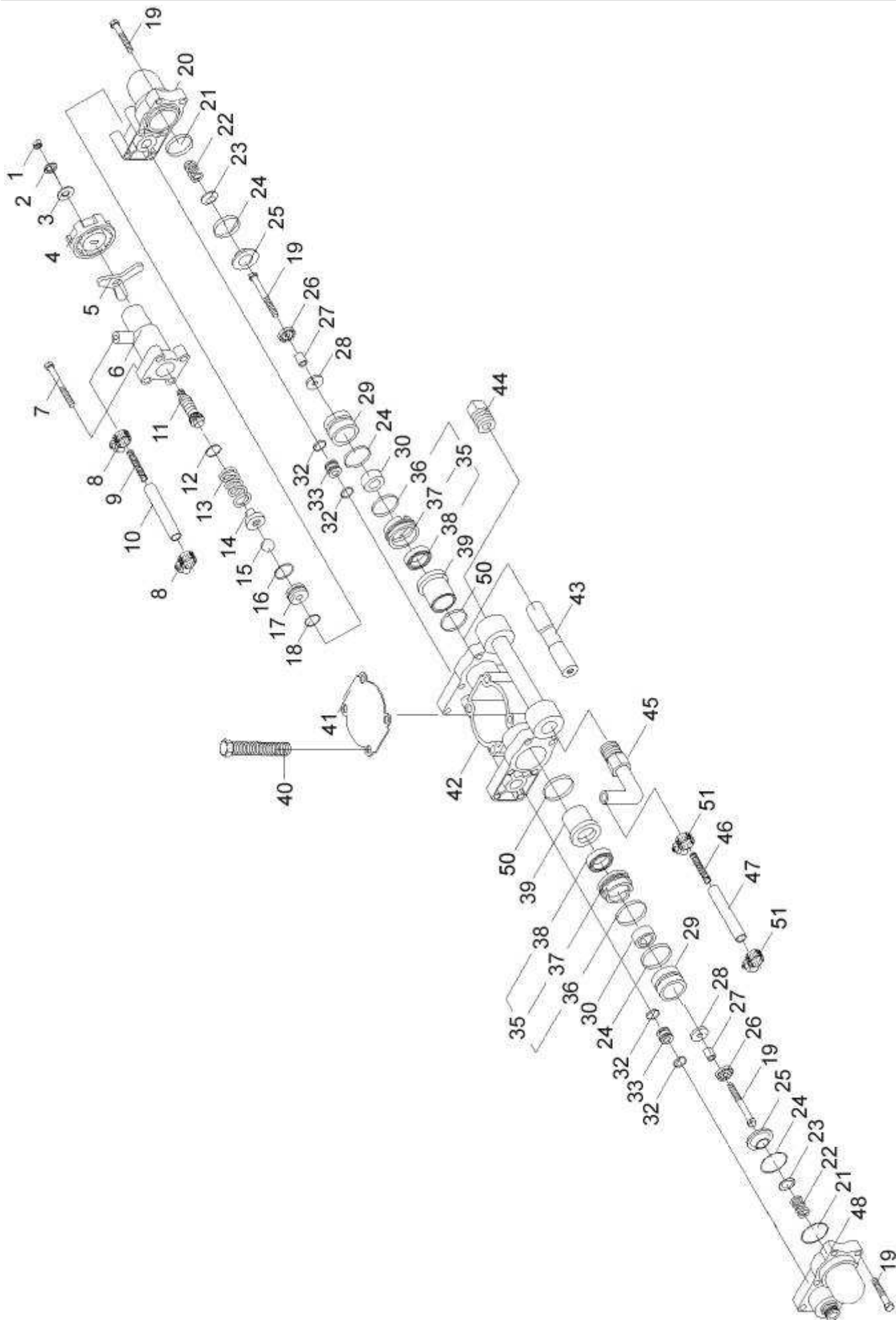

Bild-Nr. Pos.-No. Pos.-No. Pos.-No.	Bestell-Nr. Order-No. No. de Cde Ref.-Nr.	Menge Quantity Nombres Cantidad	Spritzrohr	Spray wand	Tube de pulvérisation	Tubo
1	76 926 068	1	Hochdruckschlauch	High pressure spraying Hose	Tube haute pression	Tubo alto presion
2	76 926 085	1	Schlauchverbindung enth. (-> 2, 3	Twirl Joint incl. (-> 2, 3	Connection y inclus: (-> 2, 3	Conexion incl. (-> 2, 3
3	76 92636901	1	O-Ring <-)	O-ring <-)	Joint torique <-)	Anillo <-)
4	06 10 589	1	Griff enth. (-> 4 - 6	Handle grip incl. (-> 4 - 6	Poignee y inclus: (-> 4 - 6	Empunadura incl. (-> 4 - 6
6	76 926 0700	1	Dichtung <-)	Gasket <-)	Joint <-)	Junta <-)
7	76 926 069	1	Manometer	Pressure Gauge	Manometre	Manometro
8	76 433 070	1	Spritzrohr	Spraying pipe	Tuyau pulvérisateur	Tubo pulverizacion
9	49 00 182	1	Doppeldüse enth. (-> 9 - 13	Y-shape Nozzle Assembly incl. (-> 9 - 13	Buse double y inclus: (-> 9 - 13	Tobera doble incl. (-> 9 - 13
10	76 120 0506	1	Doppeldüse	Y-shape Nozzle body	Buse double	Tobera doble
11	76 120 0502	2	Düsenfilter	Nozzle filter with Gasket	Filtre de buse	Filtro de tobera
12	76 120 0503	2	Düsenplatte	Nozzle plate	Plaque de buse	Placa de tobera
13	76 120 0505	2	Mutter, UW<-)	Cover Nozzle plate <-)	Ecrou <-)	Tobera doble <-)
14	76 926 086	1	Dichtung	Gasket,	Joint	Junta
15	76 926 0701	1	Dichtung	Gasket,	Joint	Junta

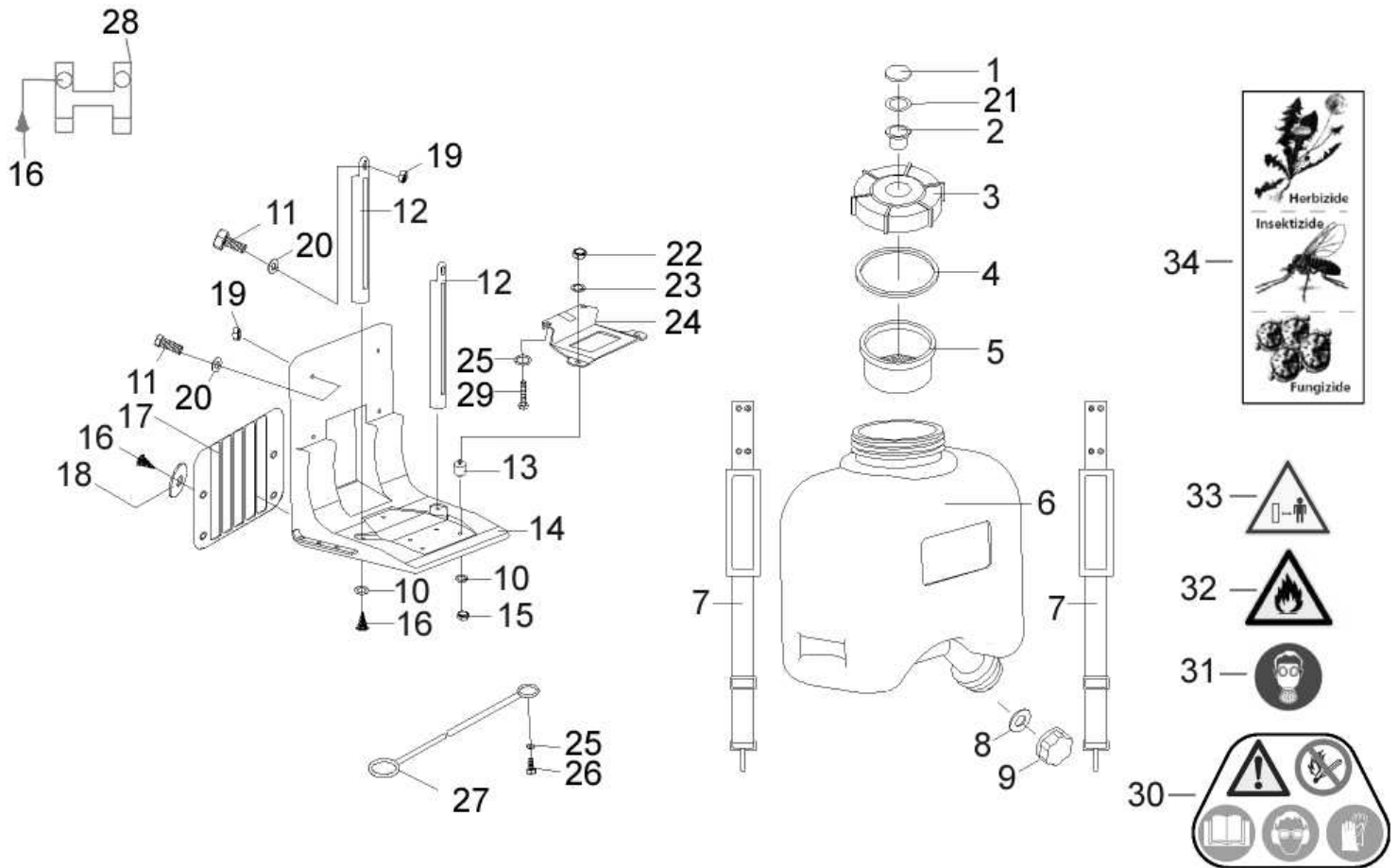

4900185 - LANCIA
INOX 120 cm CON
UGELLO REGOLABILE

Bild-Nr. Pos.-No. Pos.-No. Pos.-No.	Bestell-Nr. Order-No. No. de Cde Ref.-Nr.	Menge Quantity Nombres Cantidad	Zubehör Umbausatz Stäuben Nicht im Seriengerät enthalten 3 Fach Düsenlanze	Accessories Dusting attachment Not included in standard supply 3 Holes Fan Rod	Accessories Dispositif de poudrage Non-inclus dans la livraison.	Accesorios Dispositivo de espolvoreo No forman parte de equipo
1	4900181	1	3 Fach Düsenlanze	SPRAY LANCE	LANCE AVEC 3 BUSES	TUBO CON TOBERAS
2	0610592	1	Sprühstab	Spraying pipe	Tuyau pulverisateur	Tubo pulverizacion
3	0610553	3	Filter	Nozzle filter with Gasket	Filtre de buse	Filtro de tobera
4	0610554	3	Dichtung	Gasket,	Joint	Junta
5	0610555	3	Düsenplatte	Nozzle plate	Plaque de buse	Placa de tobera
6	0610556	1	Mutter	NUT	ECROU	TUERCA

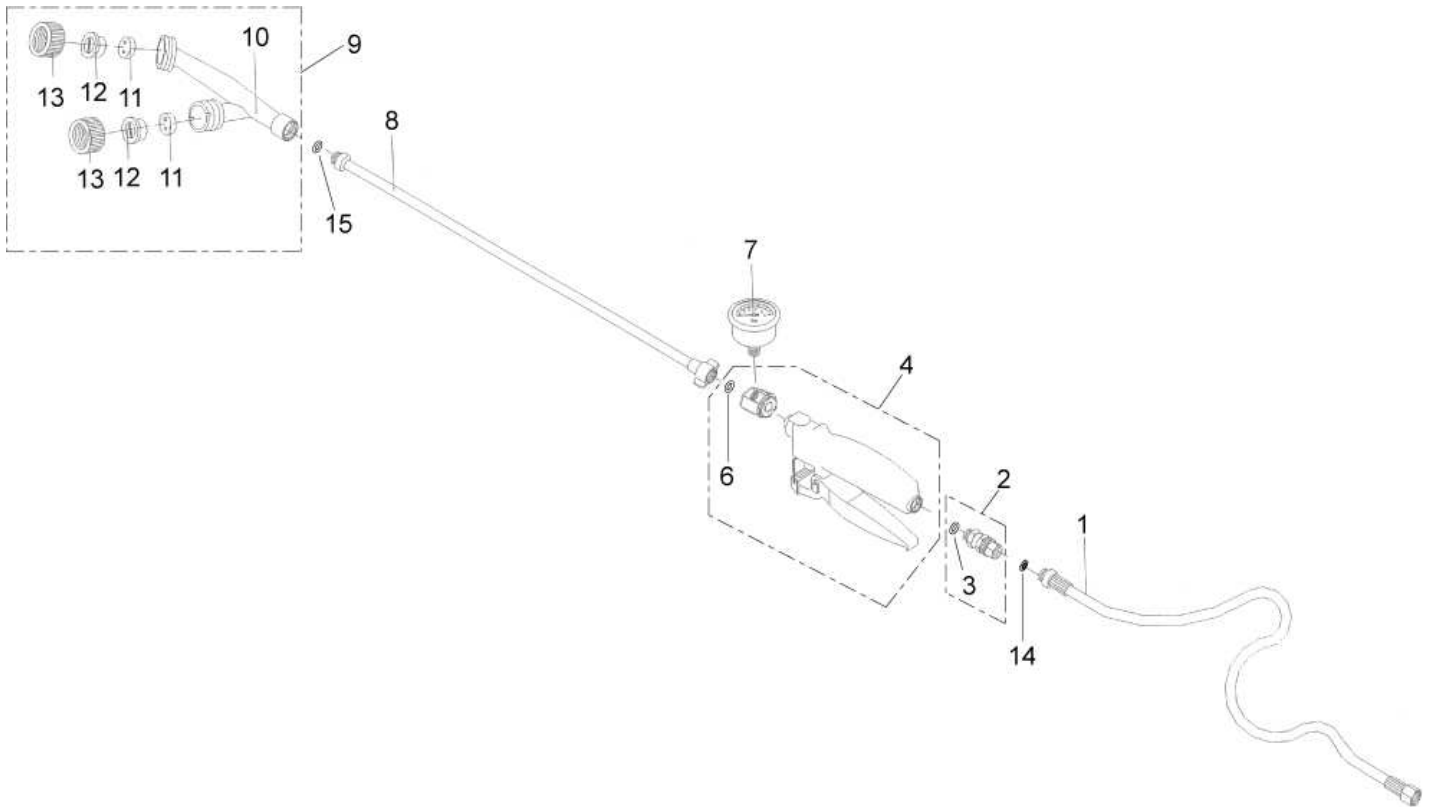
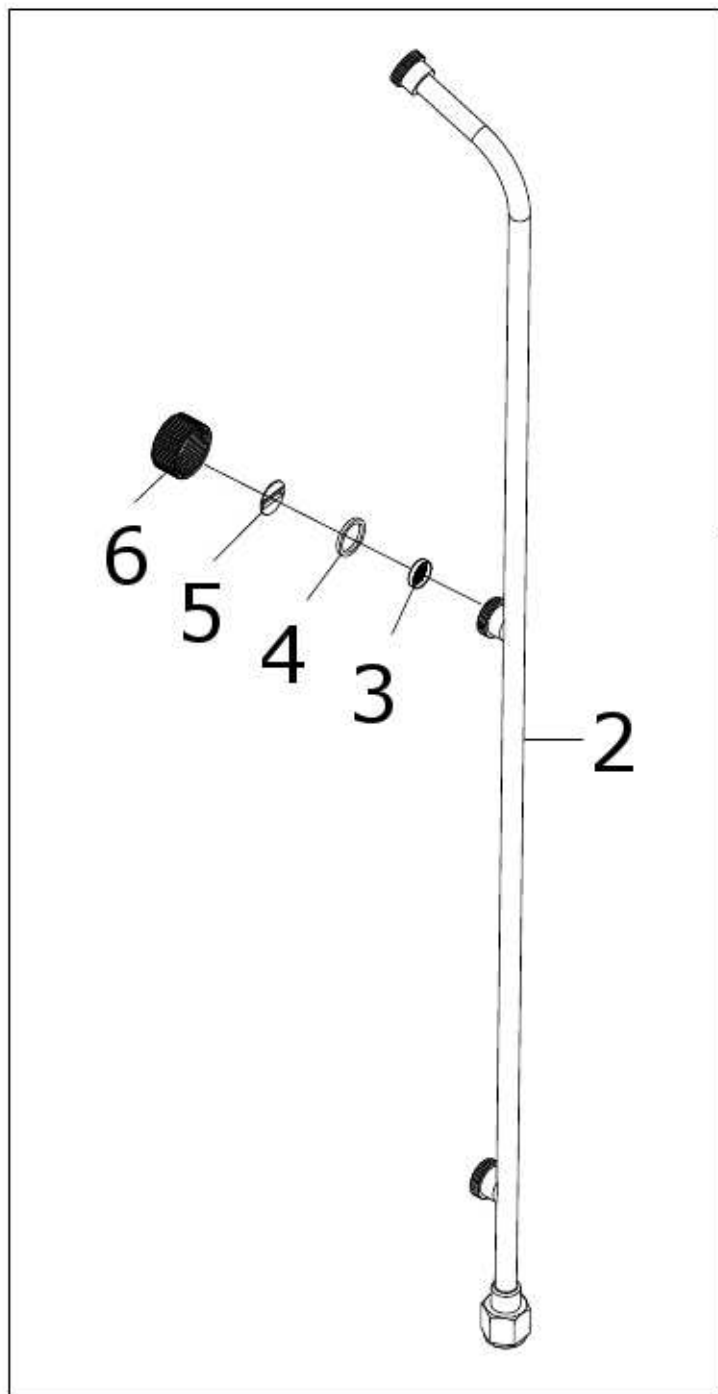

Bild-Nr. Pos.-No. Pos.-No. Pos.-No.	Bestell-Nr. Order-No. No. de Cde Ref.-Nr.	Menge Quantity Nombres Cantidad	Zubehör Umbausatz Stäuben Nicht im Seriengerät enthalten 3 Fach Ringdüse	Accessories ULV dosage control kit Not included in standard supply 3 Holes Cicle Nozzle	Accessories Dispositif de poudrage Non-inclus dans la livraison.	Accesorios Dispositivo de espolvoreo No forman parte de equipo
1	4900184	1	3 Fach Ringdüse	3 Holes Cicle Nozzle	TUYERE ANNULAIRE 3 BUSES	TOBERA ANULAR
2	761201604	1	Drallkoerper			
3	761201605	3	O-Ring <-)	O-ring <-)	Joint torique <-)	Anillo <-)
4	761201603	3	Düsenplatte	Nozzle plate	Plaque de buse	Placa de tobera
5	761201602	3	Mutter	Cover Nozzle plate <-)	Ecrou <-)	Tobera doble <-)

Bestell-Nr. Order-No. No. de Cde Ref.-Nr.	Menge Quantity Nombres Cantidad	Seite Page Page Pagina	Bestell-Nr. Order-No. No. de Cde Ref.-Nr.	Menge Quantity Nombres Cantidad	Seite Page Page Pagina	Bestell-Nr. Order-No. No. de Cde Ref.-Nr.	Menge Quantity Nombres Cantidad	Seite Page Page Pagina	Bestell-Nr. Order-No. No. de Cde Ref.-Nr.	Menge Quantity Nombres Cantidad	Seite Page Page Pagina
00 10 123	4	2	76 926 006	1	5	76 959 046	1	3	76 959 206	4	3
00 11 105	1	2	76 926 007	1	5	76 959 047	1	3	76 959 208	1	5
00 18 193	2	5	76 926 008	1	5	76 959 048	2	3	76 959 209	3	5
00 20 116	2	2	76 926 009	2	5	76 959 049	1	3	76 959 210	2	2
00 28 121	6	5	76 926 014	1	2	76 959 050	1	3	76 959 210	12	3
00 66 455	1	2	76 926 016	1	2	76 959 051	2	3	76 959 2111	1	2
00 68 239	1	5	76 926 018	3	5	76 959 052	1	3	76 959 2121	2	2
00 68 425	1	5	76 926 021	1	2	76 959 053	1	3	76 959 214	4	2
00 68 429	1	5	76 926 024	2	3	76 959 054	1	3	76 959 2141	6	5
00 68 619	1	5	76 926 024	2	3	76 959 056	2	3	76 959 215	3	5
00 68 621	1	5	76 926 025	1	5	76 959 057	1	3	76 959 2151	1	3
06 10 553	3	7	76 926 026	1	2	76 959 058	1	3	76 959 216	12	2
06 10 554	3	7	76 926 039	1	2	76 959 059	1	3	76 959 216	1	3
06 10 555	3	7	76 926 068	1	6	76 959 060	1	3	76 959 2161	3	2
06 10 556	3	7	76 926 069	1	6	76 959 061	1	3	76 959 2161	12	5
06 10 589	1	6	76 926 070	1	6	76 959 062	1	3	76 959 217	1	3
06 10 592	1	7	76 926 0701	1	6	76 959 065	1	3	76 959 217	8	5
06 926 014	1	2	76 926 085	1	6	76 959 066	1	3	76 959 219	8	5
06 926 018	1	2	76 926 086	1	6	76 959 067	1	3	76 959 224	4	5
49 00 182	1	6	76 92636901	1	6	76 959 076	4	3	76 959 4950	2	3
76 120 0502	2	6	76 959 010	6	5	76 959 077	1	3	76 968 001	1	5
76 120 0503	2	6	76 959 022	1	3	76 959 087	2	3	76 968 002	1	5
76 120 0505	2	6	76 959 024	1	3	76 959 088	2	3	76 968 013	2	5
76 120 0506	1	6	76 959 025	1	3	76 959 092	2	3	76 968 019	1	5
76 120 1602	3	8	76 959 027	1	2	76 959 093	2	3	76 968 019	1	5
76 120 1603	3	8	76 959 028	1	2	76 959 094	2	3	77 926 015	1	2
76 120 1604	3	8	76 959 031	1	2	76 959 095	2	3	77 926 016	1	5
76 120 1605	3	8	76 959 033	1	2	76 959 096	2	3	77 959 004	1	5
76 926 005	1	5	76 959 034	1	2	76 959 203	4	3	77 959 010	6	5
76 27 076	2	3	76 959 035	3	2	76 959 204	2	2	77 959 065	1	3
76 433 023	1	3	76 959 037	1	2	76 959 205	2	2			
76 433 070	1	6	76 959 040	4	3						
76 926 002	1	5	76 959 041	2	3						
76 926 003	1	5	76 959 042	2	3						
76 926 004	1	5	76 959 044	2	3						
76 926 005	1	5	76 959 045	2	3						

D

Allgemeine Richtlinien für die Bestellung von Original SOLO Ersatzteilen:

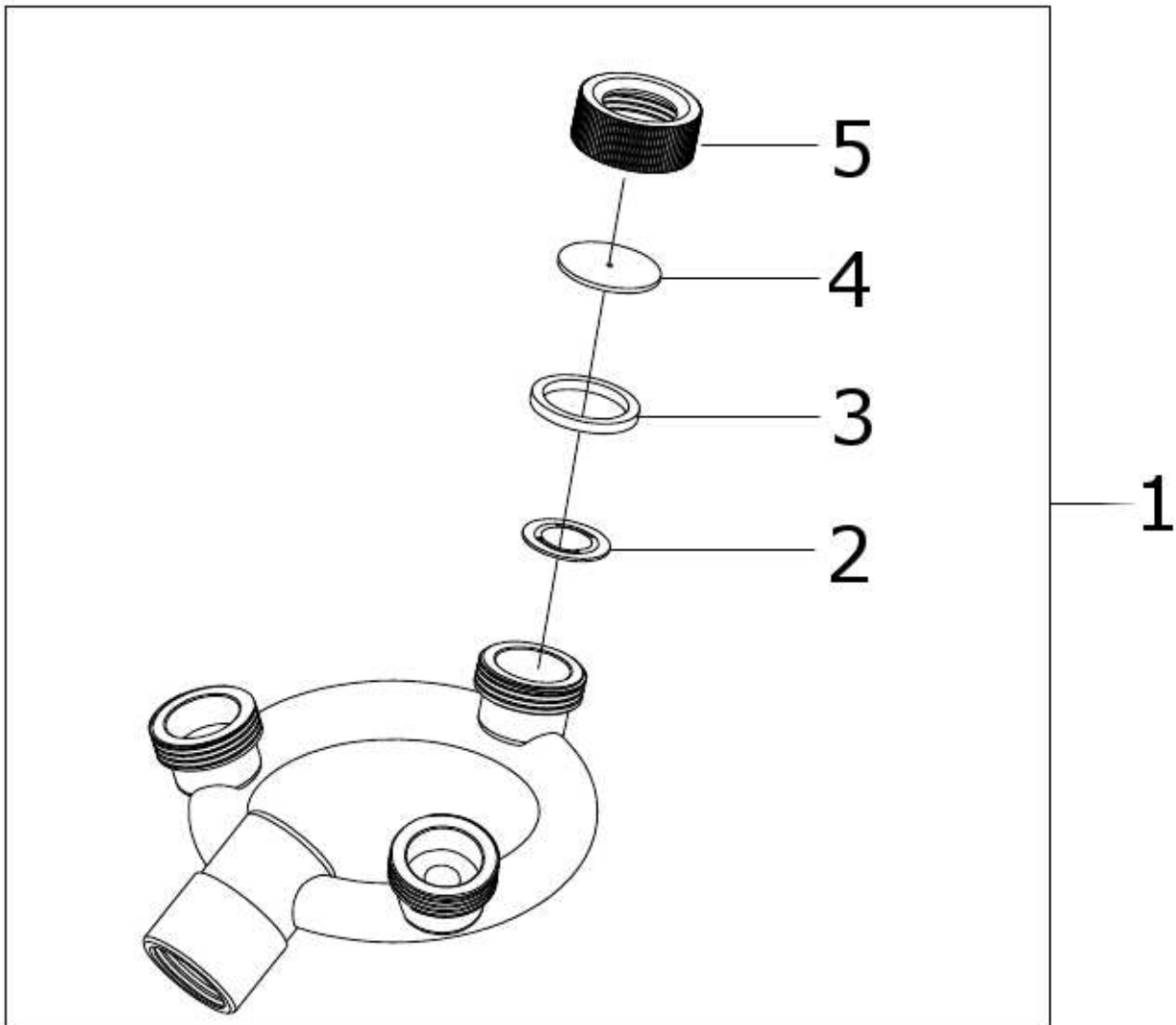
Voraussetzung für eine reibungslose Erledigung sind folgende Angaben:

1. Ersatzteil-Bestellnummer
2. Gewünschte Anzahl
3. Typenbezeichnung des Geräts

Diese Ersatzteilliste ist für die Lieferung und Ausstattung von SOLO Erzeugnissen unverbindlich. Im Interesse der technischen Weiterentwicklung bleiben Konstruktionsänderungen vorbehalten.

GB

General Directions for Ordering Original SOLO Spare Parts:

For correct and diligent processing of your order, please give the following information:

1. Spare Part number
2. Quantity
3. Model and serial number
4. Shipping instructions

Delivery is made in accordance with our general sales and delivery conditions. This spare parts list is non-committal for us with regard to delivery and layout of SOLO products. In favour of technical

F

Directives générales pour les commandes de pièces de rechange d'origine SOLO:

Il est indispensable de préciser dans toutes les commandes de pièces:

1. le numéro de référence de la pièce
2. la quantité
3. le type de la machine
4. le mode d'expédition

Les livraisons sont effectuées dans le cadre de nos conditions générales de vente. Toutes modifications réservées.

E

Directivas Generales de pedido de la firma SOLO:

Por adelantado de un arreglo sin dificultades necesitamos siguientes indicaciones:

1. Número de repuesto
2. Numero de cantidad
3. Modelo y número de serial
4. Instrucción de Envío

Esta lista de repuestos no es obligatoria para los envíos y/o forma de equipo de los productos SOLO. En el interés del constante desarrollo debemos reservarnos

improvements, design modifications are
subject to change without notice.

el derecho de cambios.

<http://www.solo-germany.com>
e-mail: info@solo-germany.com

Telefon 07031/301-0
Telefax 07031/301-130
Export 07031/301-149

Zentral-Ersatzteilservice
Telefon 07031/301-209
Telefax 07031/301-206

SOLO Kleinmotoren GmbH
Postfach 60 01 52
D-71050 Sindelfingen Germany